

MOUNTING INSTRUCTION FOR EI₂60 SLIDING DOOR

MODELS

MS0711EI₂60

AS0711EI₂60

Content

General conditions	3
Content of delivery.....	4
Types of walls/fixings.....	5
Installation.....	6
Tools for mounting.....	6
Control of wall opening	6
Distances between wall and frame.....	7
Mounting of counter frame (option)	7
Mounting of frame	8
Mounting of sliding rail.....	10
Mounting of door leaf	11
Mounting of bottom guide	13
Mounting of counterweight with and without reversing wheel	14
Covers (option)	16
Belt drive (AS0711EI260)	17
Mounting of motor.....	17
Mounting of toothed belt and connectors	18
Control system, cables and photo cells (AS0711EI260).....	19
Control system and cables for motor and encoder sensors.....	19
Cables for door.....	19
Plastic pipe frame	20
Control panel/emergency stop	21
Photo cells.....	21
Power supply	22
Final control after mounting.....	23
Documentation.....	23
Maintenance and service.....	23

General conditions

- It is essential for the fire properties of the fire door that the door is correctly installed in accordance with these instructions.
- The fire door shall be mounted by qualified personnel.
- The person/company, who mounts the fire door, is responsible for that the door is mounted correctly.
- The frame must not be filled with concrete.
- Do not change the content or texture of the insulation of the frame. It will impair the fire properties of the fire door.
- Do not mill, cut, drill or do any other machining on the door or frame.
- Inflammable flooring, ex. carpet, must not go through the wall opening or underneath the door.
- Door sign or other signs moreover shall be visible, valid and must not be covered or painted.
- If door plate or other signs moreover is damaged or disappears the door must not be used as a fire door until it is identified as a fire door and the signs are re-established. The identification shall be done by the fire authority.
- The owner of the fire door is responsible for that the door is operational.
- Changes on the door is not allowed, as it will degrade the fire resistance of the door.

Content of delivery

Description	Comment
Frame with attached labyrinths connectors. Frame can be divided. Connector for cover attached (option).	
Door leaf delivered in unassembled sections	
Sliding rail (can be divided in A- and B sliding rail) with endstop, carrying consoles, wheel for wire and rollers. Connector for cover attached (option).	
Counterweight	
Counter frame, 3 or 4 frame parts incl. connectors	Option
Door magnet for use for smoke alarm (delivered mounted on sliding rail)	Option
Support for sliding rail	Only for light wall
Kit with guide rail for floor, incl. fasteners	
Door leaf prepared with connectors, handles and rollers	
Necessary bolts, muster, screws and plugs for installation	
Sliding rail cover	Option
Brake for counterweight	
Automatic with control system and motor incl. cables, encoder and encoder sensor	Only for AS0722E1260
Control panel, photo cells and emergency stop incl. cables	Only for AS0722E1260

Types of walls/fixings

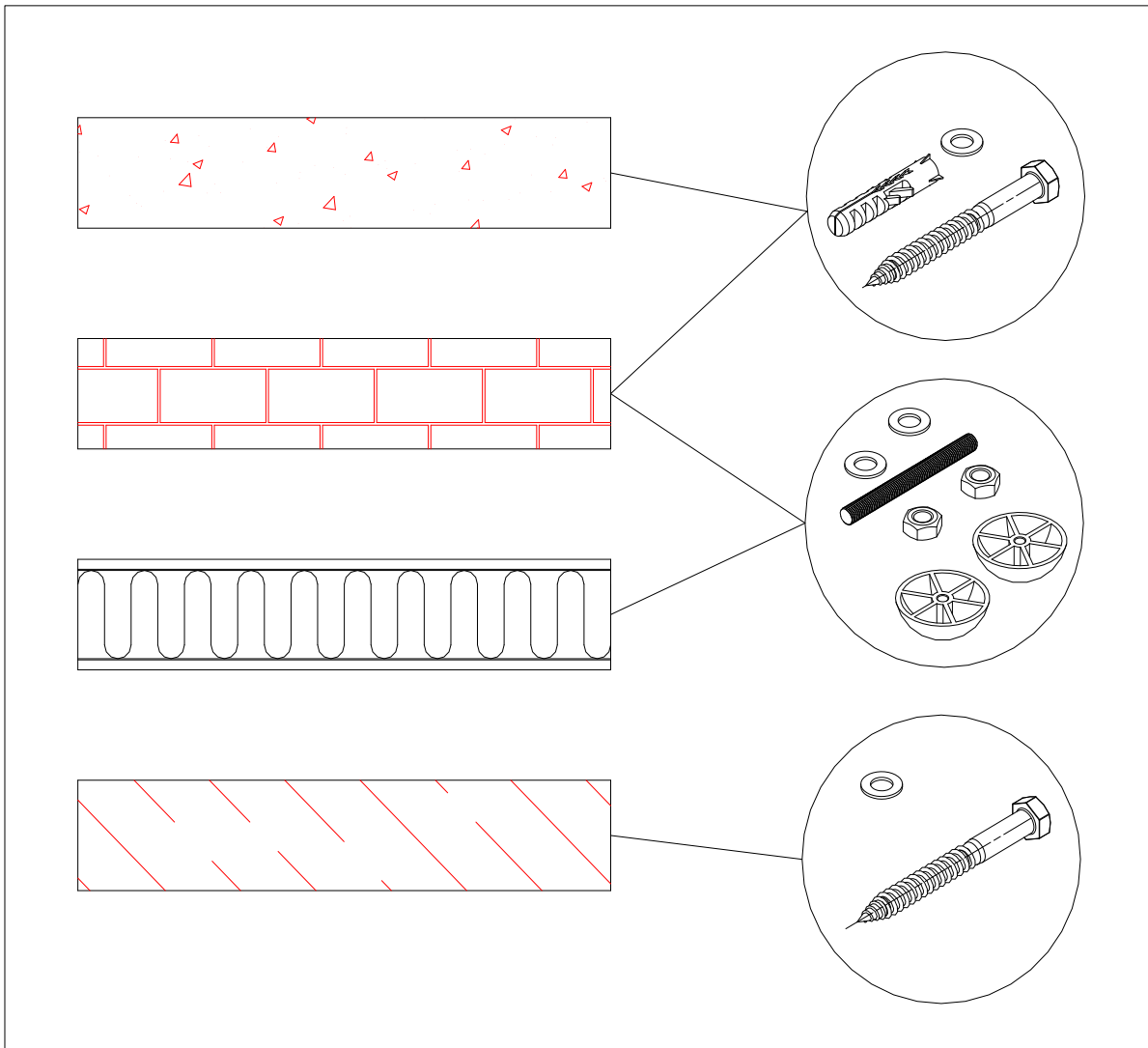

The fire sliding door must be installed in a fire wall.

The sliding door is approved in the following wall types:

- 150 mm rigid wall (concrete, lightweight concrete, aggregated concrete, masonry) with a min. density of 575 kg/m³.
- 100 mm panelwall (EI60) made similar as Kingspan KS1150 RF C.
- Protected (EI60) structural steel supporting construction.

Approved fasteners:

Rigid wall: Screws or threaded rods.

Panel wall: through-going Ø8 threaded rods or bolts with nuts.

It is possible to change type of fastener provided the fixings have a melting point of min. 850°C and have an equal or better pull-out strength.

Installation

Tools for mounting

Level
Clamps
Power drill/screwdriver/riveter
Socket wrench M13
Bolts/screws/plugs etc.
Sealant (eventual)
Ladder/lift
Lifting equipment (eventual)

Control of wall opening

Make sure the wall opening is level and perpendicular and in accordance with the order confirmation.

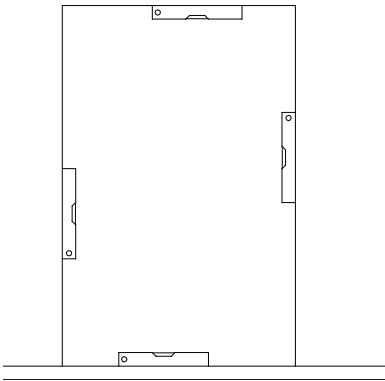

Kontroller om gulv og hul er i vater.
Control if floor and hole is in level.

Kontroller mål på murhulsåbning.
Control measurement of wall opening.

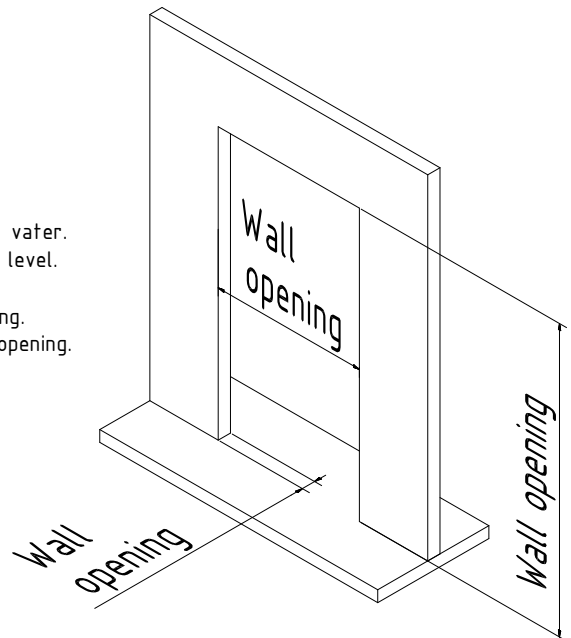

Distances between wall and frame

At any point around the frame, the distance from the wall opening to the inside of the frame must be at least 15 mm. The minimum distance of 15 mm also applies even if the door is fitted with a counter frame and/or seal. See the drawings below.

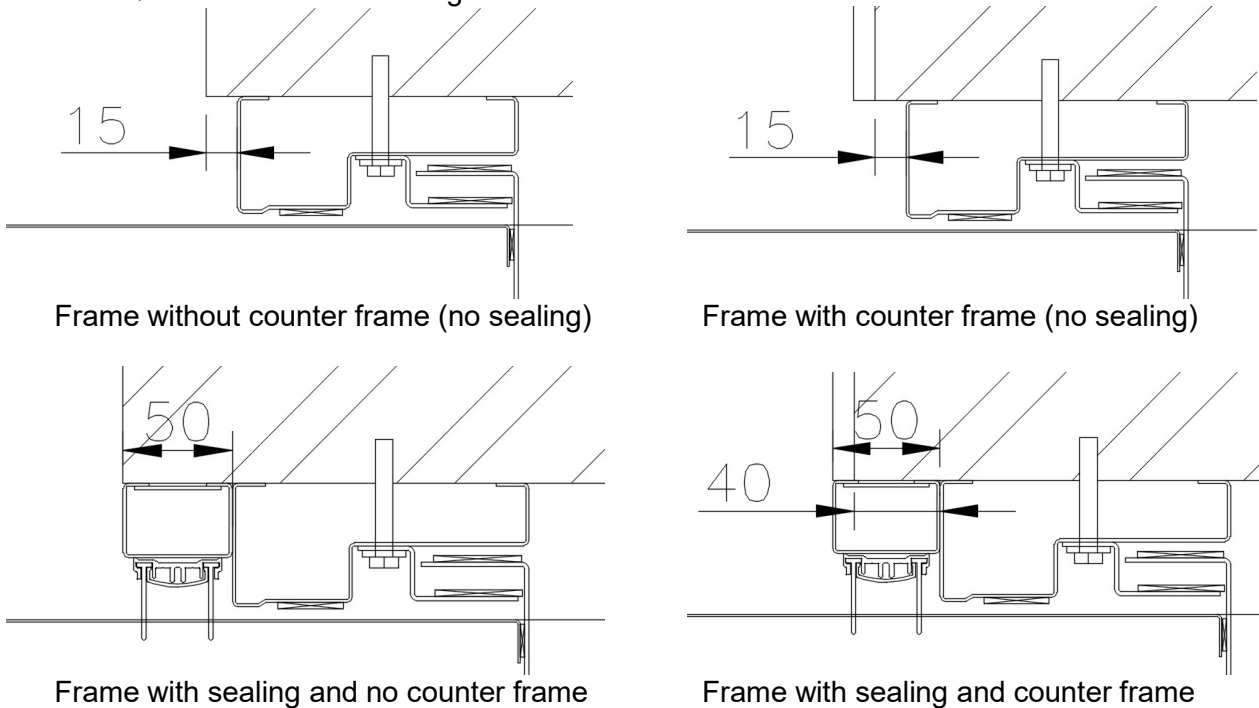

Mounting of counter frame (option)

Optionally counter frame should always be installed before the frame.

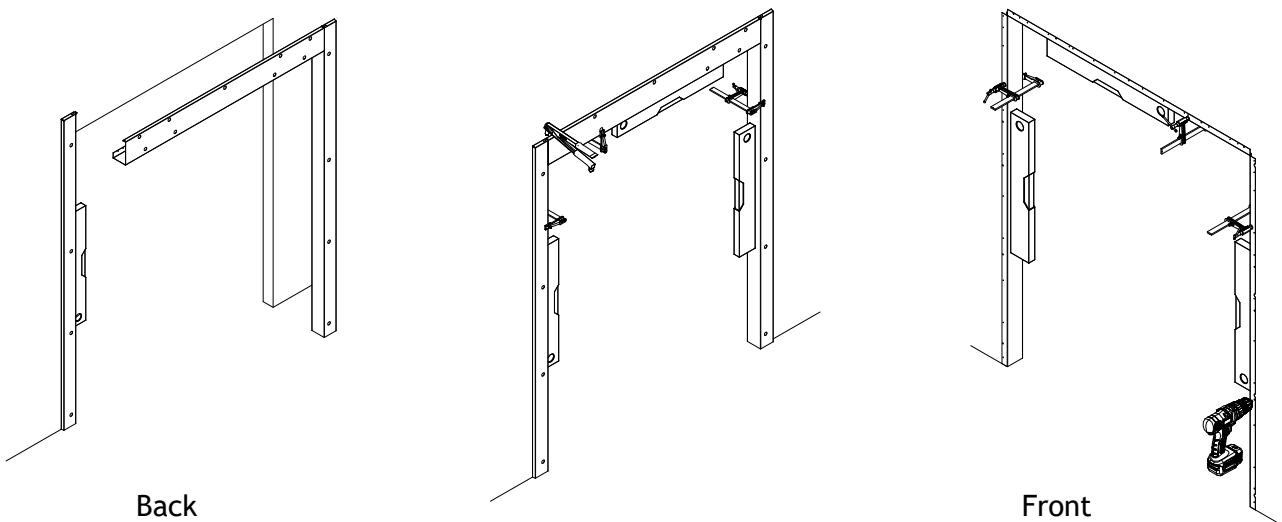

The counter frame is held against the wall with clamps (opposite the side of the wall where the sliding door is to be fitted). Before the final fastening of the counter frame, it has to be checked that the counter frame is in level both horizontal and vertical. The counter frame is prepared with mounting holes and underlying mounting connectors where the counter frame has to be fastened. Drill holes through the mounting holes and fasten the counter frame with the supplied fasteners.

Mounting of frame

Frame is installed on the wall.

Make sure the wall is strong enough to carry the door. If that is not the case the wall should be reinforced or a self-supporting frame (fire protected) should be installed.

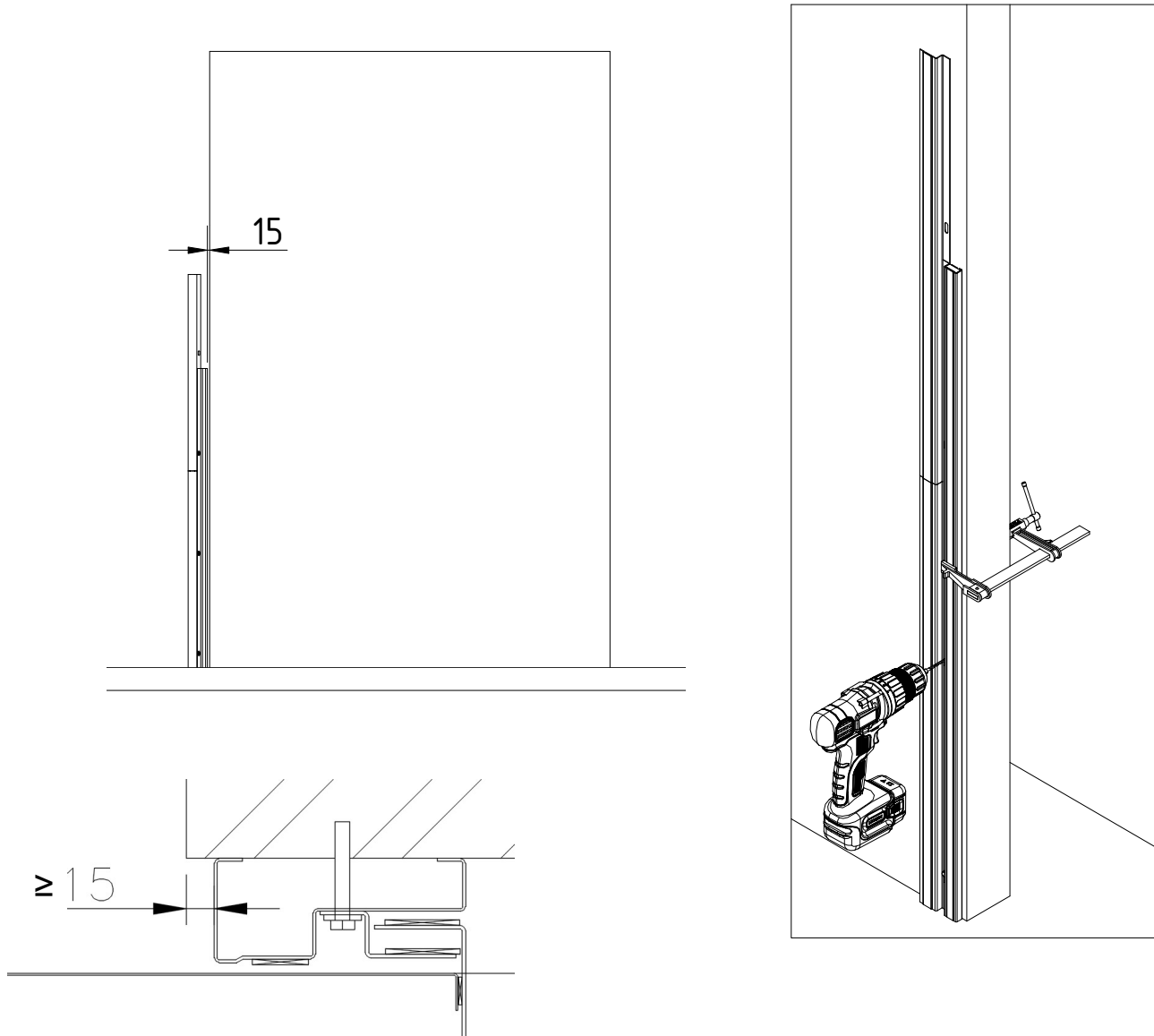

For wide wall openings the frame will at most times be delivered divided. The front frame leg of the door should be placed against the wall minimum 15 mm from the wall opening. The second part of the frame should be pushed into the first part and then fastened to the wall with clamps.

If the frame is delivered in one piece, the frame is placed against the wall and fastened with clamps. The frame should be placed in level both horizontal and vertical and fastened with clamps. Adjust the frame to make sure it is in level both horizontal and vertical.

The distance from the inside of the frame to the wall opening must not be less than 15 mm (see the above drawing). If the distance is not fulfilled, the wall opening has to be adjusted, so the requirements can be fulfilled. This adjustment is to be agreed with the owner of the door. The company who mounts the door is responsible for this agreement.

Fasten the frame at the wall with the supplied fasteners in all the holes in the frame.
Before the final fastening the following has to be checked:

- The frame is in level both horizontal and vertical.
- The frame is standing on the floor.

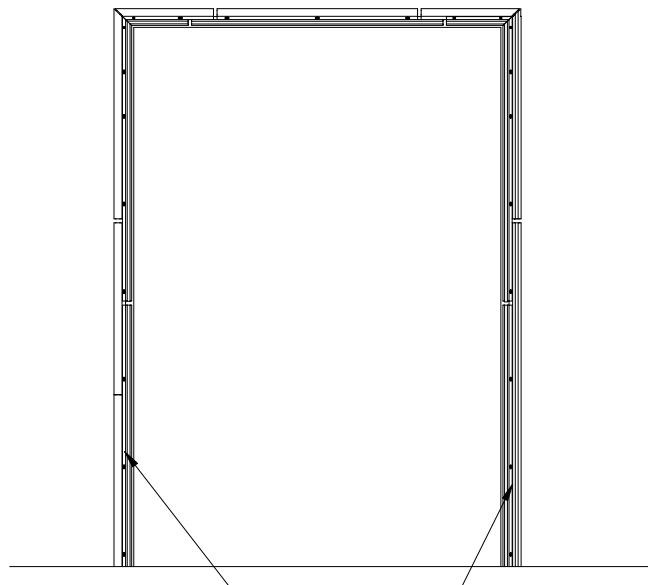
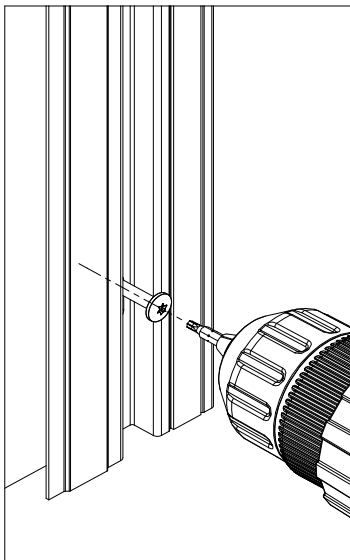

Forkant og bagkant monteres parallelt.
Front and rear to be mounted parallel.

NB! Do not use foam for mounting or fixing the frame.

Mounting of sliding rail

The sliding rail with fastened consoles are lifted above the door opening (with accessible lifting equipment).

If the door is attached to panelwall the support for the sliding rail is placed on top of the top frame.

When installing the sliding door on rigid wall (or fire-protected construction steel structure), place the consoles for the sliding rail at a distance "B" above the top frame. The distance from the top of the frame to the bottom of the console (B) depends on the height of the labyrinth (A). Look at the drawing below.

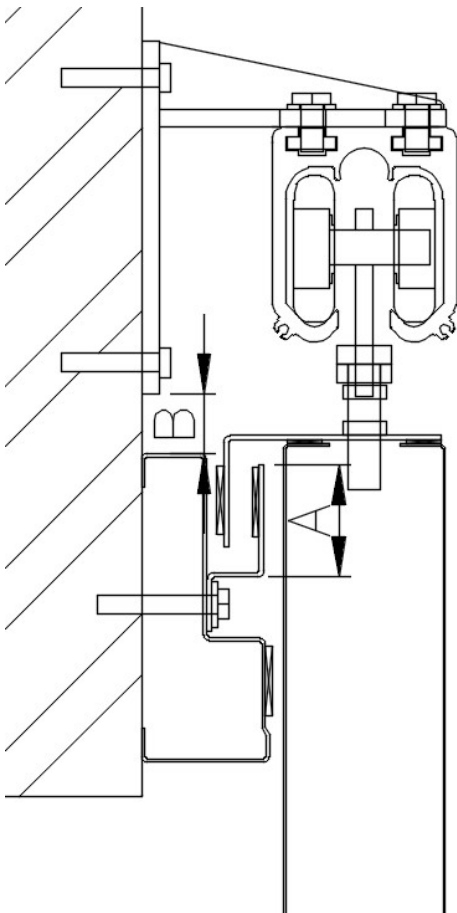

A [mm]	B [mm]
49	20
59	30
69	40

Before fastening the front console, push the sliding rail forward until the console is flush with the front of the frame leg. The console is fastened with the supplied fasteners. The console to the rear edge of the door (approx. middle bracket), make sure the sliding rail is in level (it must NOT have a slope backwards). The rest of the consoles can then be attached in a similar way, check continuously that the sliding rail is level.

If the sliding rail is split, it will consist of an A rail (over the door opening) and a B rail. The two rails come together at the console at the rear edge of the door.

The distance between the consoles must not be greater than 2200 mm.

Mounting of door leaf

The sliding wheels are assembled at the rear end of the sliding rail. The two front sliding wheels are pulled forward over the door opening. The threaded bolt underneath the wheel is dismantled and screwed in the door leaf.

Note! The door leaves are heavy, so the use of lifting gear is recommended.

The door leaf is lifted and pushed carefully under the sliding rail so that the rebate is pushed correctly into the rebate on the top frame. There is not much space.

The bolt at the top of the door leaf is fastened to the wheels using the included u-brace with nuts.

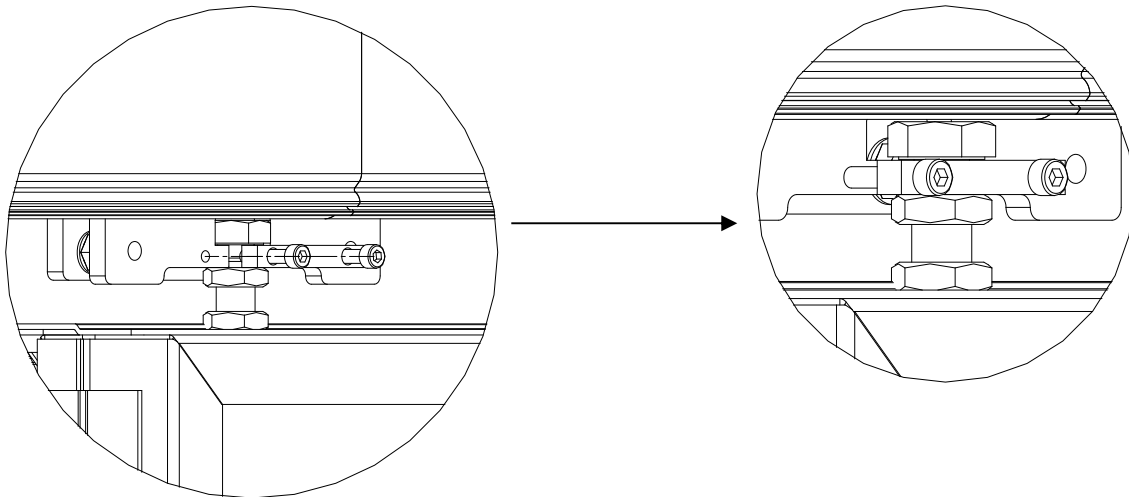

ATTENTION! It is very important that the fire seal inside the rebate is not damaged, therefore it is important that the rebates are not pushed up against each other.

When the door leaves are installed in the sliding rail, they must be adjusted so that they are in the same height. This is done by turning the nut on the bolt under the wheel. Look at figure 3.1.1.

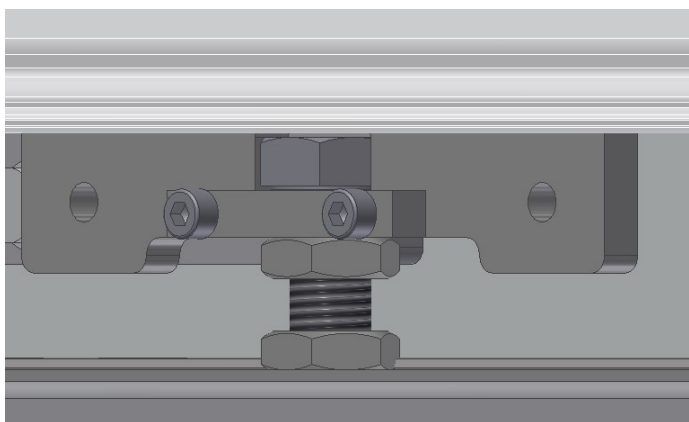

Figure 3.1.1

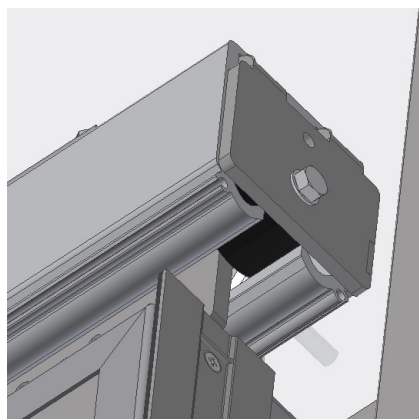

Figure 3.1.2

Push the door leaves together and make sure the Promatect material are placed in the recess along the height of the door leaves. The door leaves can optionally be held together with a transport strap. When the door leaves are held as firmly together as possible the top and bottom of the door leaves are fastened. In the top: fasten a bolt in the top edge of the door leaf. In the bottom: fasten a bolt on the surface of the door leaf from the backside.

Adjust the height of the door until the fire door slides in easily and covers the wall opening. Make sure that the distance between the door and floor does not exceed 12 mm at any place in closed position.

When the fire door is closed the distance between frame and door leaf must only be the distance necessary for the fire door to run smoothly in the sliding rail. The sliding rail can be adjusted horizontally using the oblong holes in the mounting connector (see page 10).

It is checked that the door is pushed against the rubber limit stop in the sliding rail when the door is completely closed and covers the wall opening.

If desired, the joints in the door leaf can be sealed with Sabaprotect M500.

Mounting of bottom guide

The bottom guide is installed after mounting the door leaf. The door leaf must be in the fully closed position, after which the bottom guide is carefully pushed under the door into the rebate under the door leaf until it is right at the back edge of the door leaf and cannot go any further. The door leaf is adjusted so that the distance between the vertical rebate at the rear edge of the door is approx. in the middle before the bottom guide is fixed to the floor. The location of the bottom guide will be approx. as shown on the drawing below.

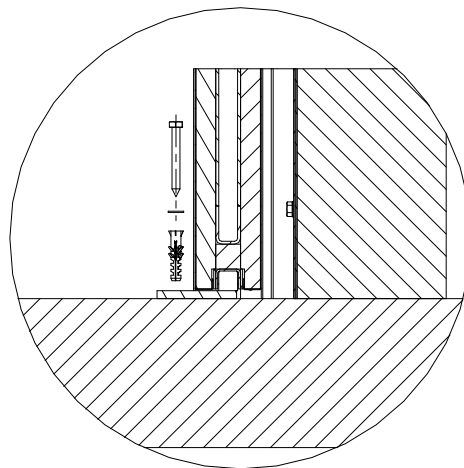
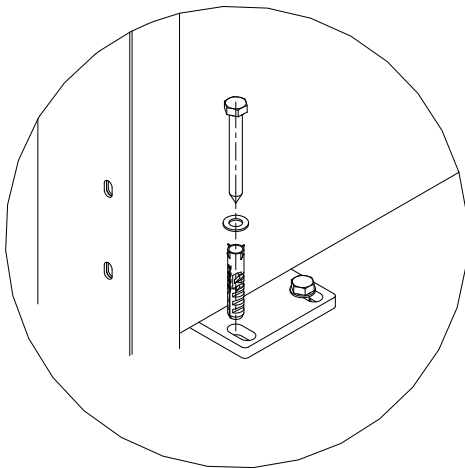

Mounting of counterweight with and without reversing wheel

The counterweight is typically placed at the front frame leg. The wire from the counterweight is attached to the wheel in front of the door leaf. The wire is fed through the hole by the wheel and made into a loop, where the wire is fastened using the supplied two plates with screws and nuts.

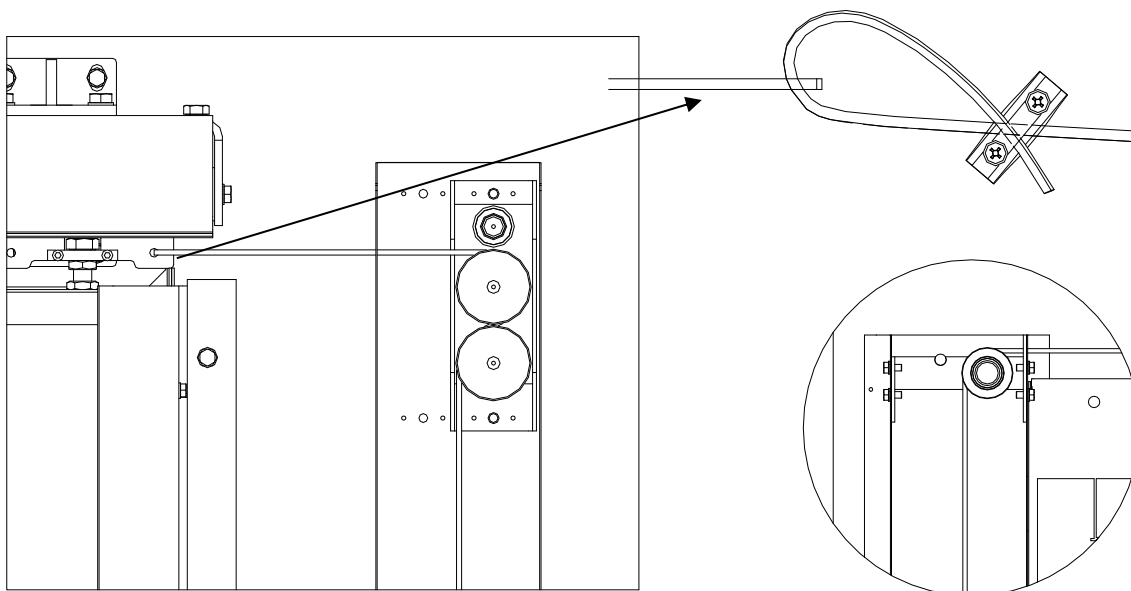

Wire by door with brake

Wire by door without brake

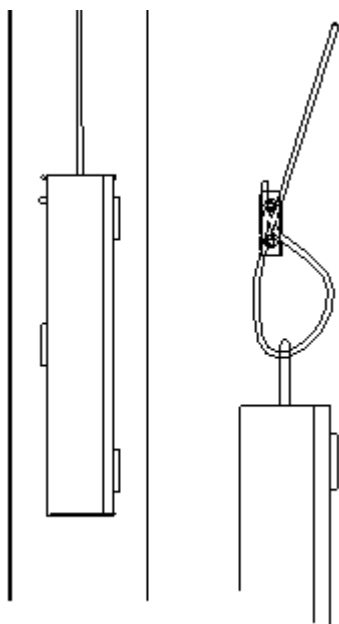

Wire by counterweight without reversing wheel

If the counterweight is placed by the rear frame leg (by the B-rail) the wire must be led through the reversing wheels placed opposite the counterweight box.

The counterweight must be made with reversing wheel if the height of the door is too low compared to the width of the door. Pass the wire through the reversing wheel placed on the counterweight and pass the wire to the top of the counterweight and fasten it by making a loop and using the delivered plates, screws and nuts. Fasten the wire on the door leaf as shown above.

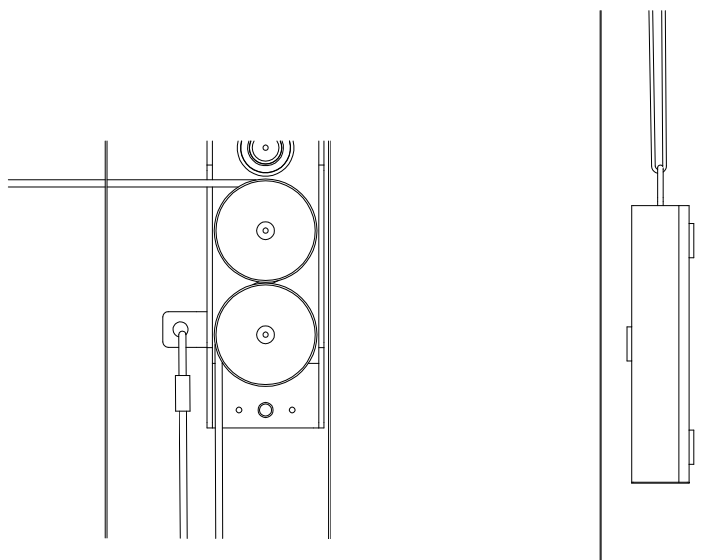

Wire by counterweight with reversing wheel

Adjust the wire to make sure the counterweight does not hit the reversing wheel in the top of the counterweight box when the door is fully open. Moreover the counterweight must always hang by the wire (it must not rest on the bottom of the counterweight box/floor) when the door is in closed position.

Covers (option)

Fasten covers to the attached connectors with the delivered bolts.

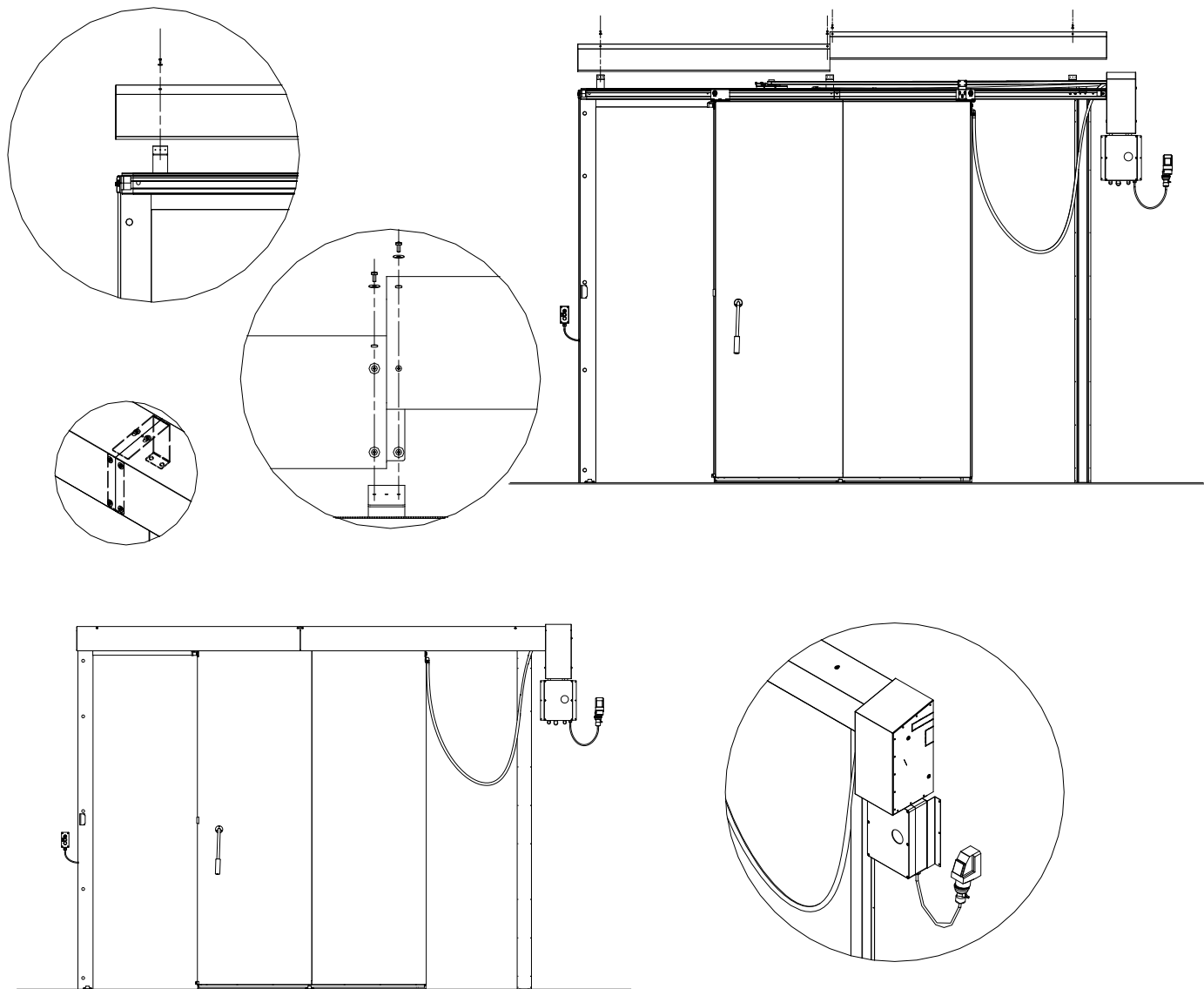

Belt drive (AS0711EI260)

The setup of the control system is described in the manual named 'Door Control'.

Mounting of motor

The motor is mounted on the end of the sliding rail with the delivered bolts, after which the motor is mounted to the wall.

Sensors are adjusted at the perforated disk using a search blade, the distance must be 0.4 mm.

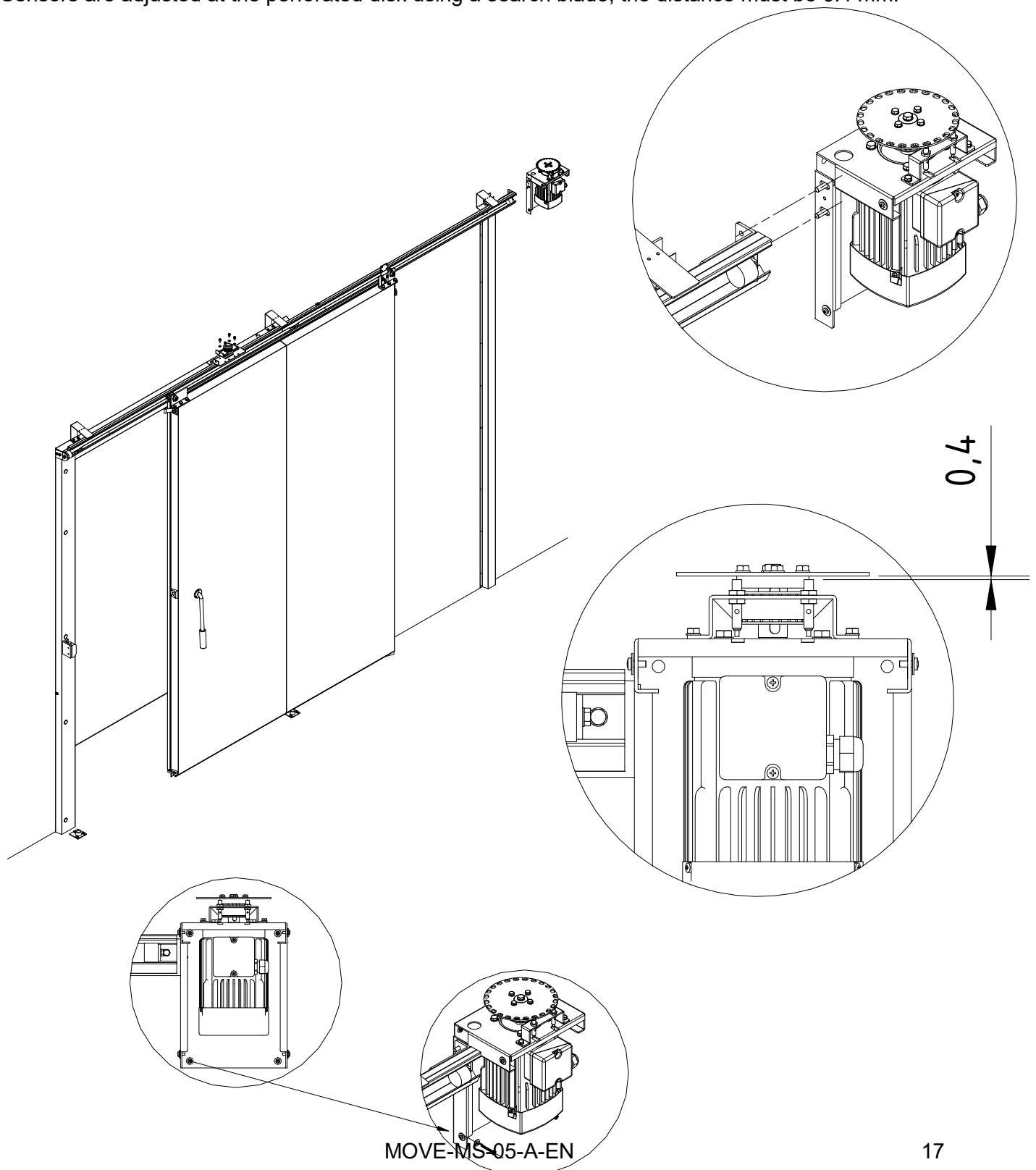

Mounting of toothed belt and connectors

Mount the connectors on the top of the door leaf.

Pass the toothed belt around the toothed wheel in top of the motor (beneath the encoder) and around the toothed wheel placed on the sliding rail.

The two ends of the toothed belt are assembled with the connector and the 4 bolts. The bolts are then tightened well so that the belt cannot be pulled out of the bracket.

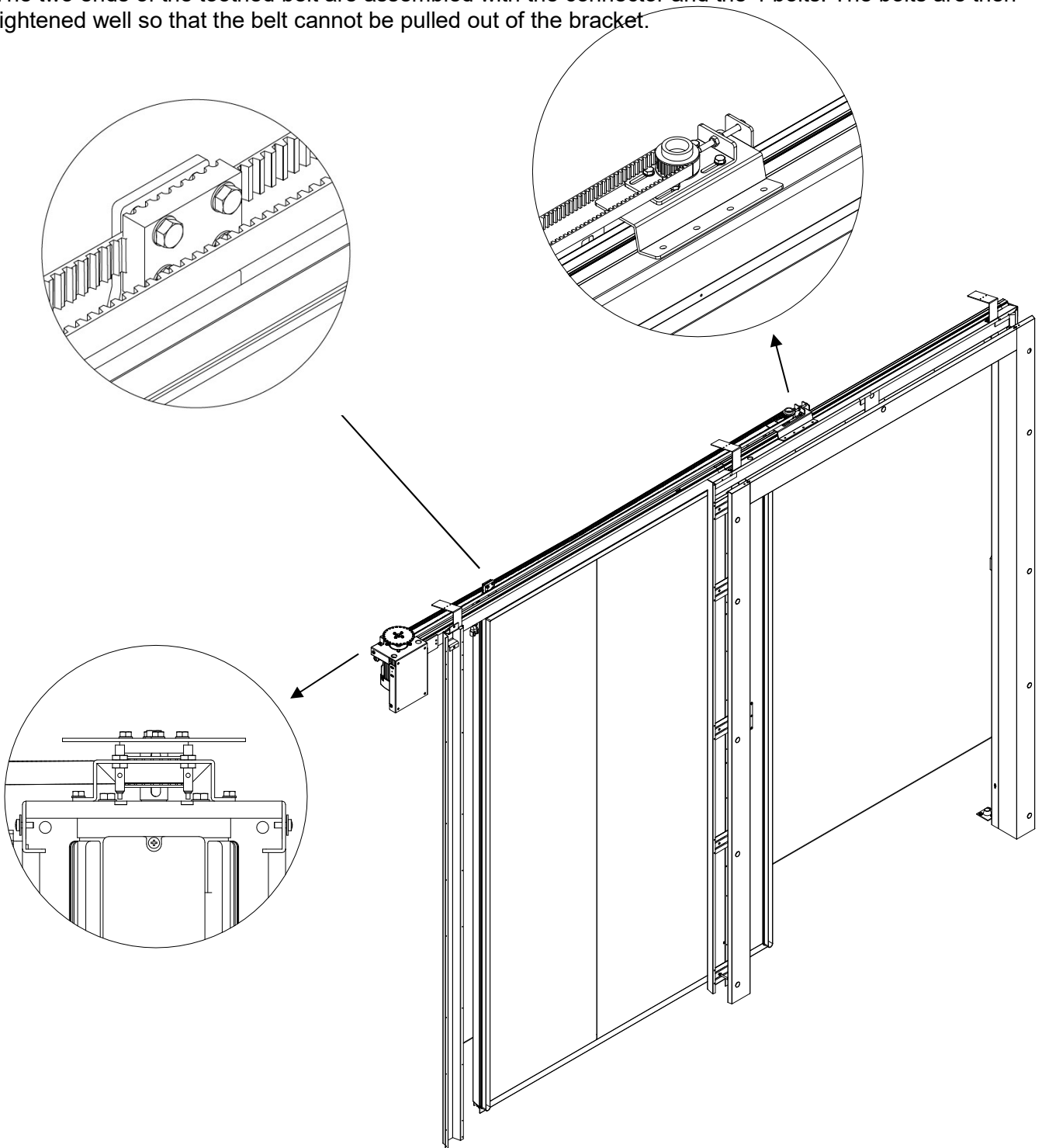

Control system, cables and photo cells (AS0711EI260)

Control system and cables for motor and encoder sensors

The figures below shows standard placement of the control system approximately 70 mm in the middle under the motor. The cable from the motor is placed behind the control box and in to the bottom of the control box (for cabling see at Door Control manual).

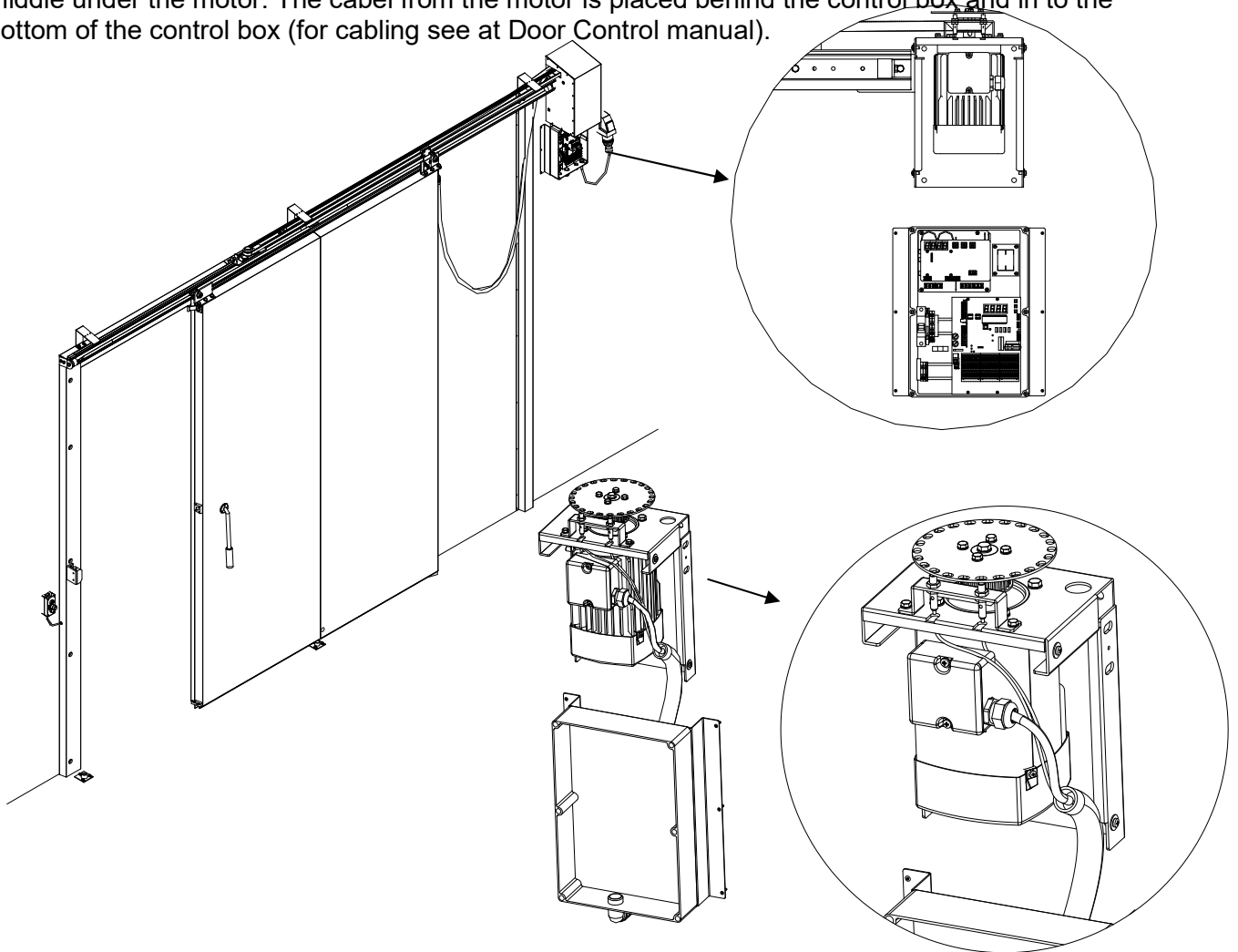

Cables for door

Plastic pipe with cables for photo cells and optionally heating cables/cables for lock is mounted on rear edge of the door leaf. Pass the plastic pipe through the motor connector, behind the control box and up in the the bottom of the control box.

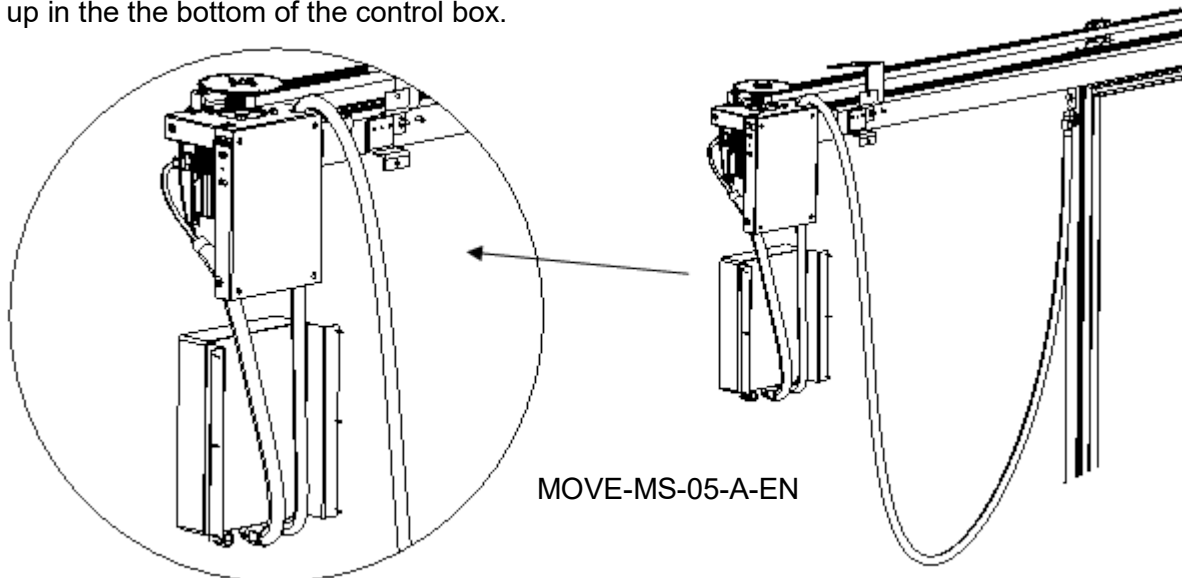

MOVE-MS-05-A-EN

Plastic pipe frame

Fasten the plastic pipe with cables for photo cells from frame and cables to control panel in the pipe connector behind the sliding rail and pass the plastic pipe down through the motor connector, behind the control box and up in the bottom of the control box.

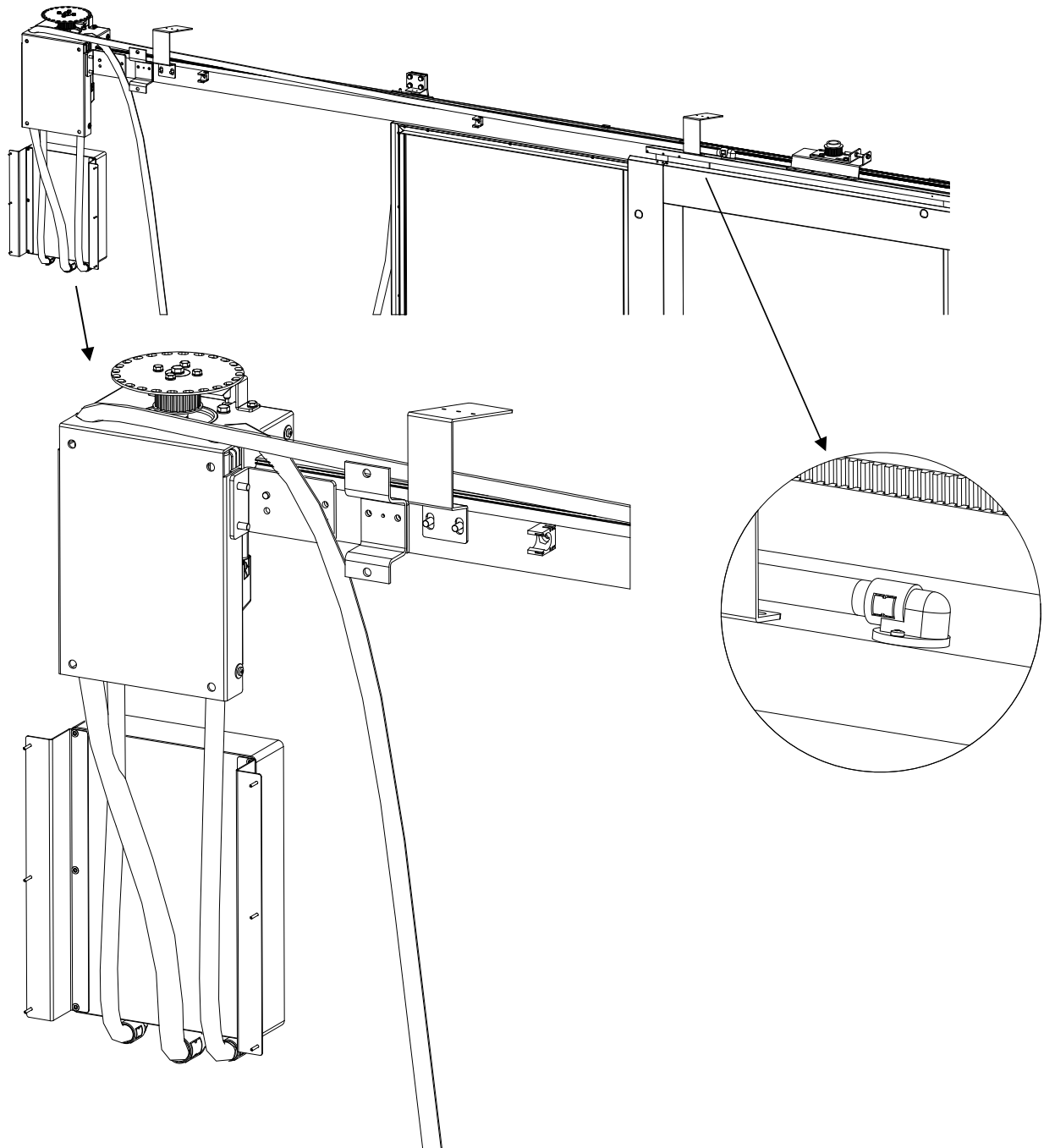

Control panel/emergency stop

Control panel with light is mounted on the wall by the front of the door. Make a hole in the wall for the cable to the control panel on the wall by the backside of the door. Place the control panels approximately 1300 mm from floor.

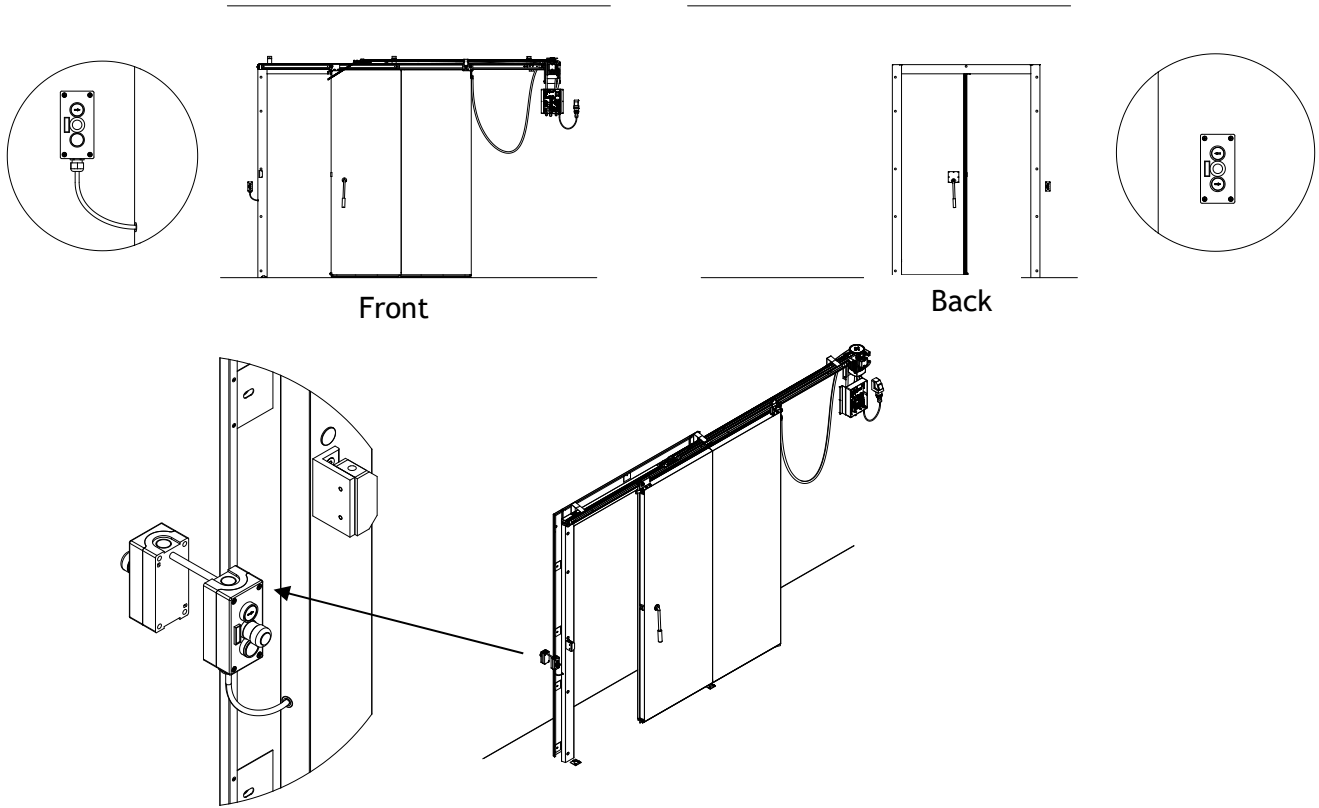
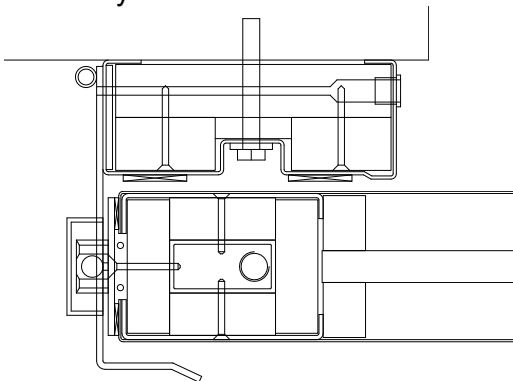

Photo cells

Photo cells can be placed vertically on the front edge of the door leaf or/and horizontally in the frame leg.

If photo cells is placed in frame leg the cable is passed to the top of the frame leg. From here the cable is passed in a steel pipe above the top of the frame and assembled in an electrical box by the control system.



If photo cells is placed on the front edge of the door leaf the cable is passed to the top of the door leaf. From here the cables is passed in a steel pipe above the door leaf and assembled in an electrical box on the rear edge of the door leaf.

Power supply

Included as standard is a red CE-conductor 16 Amp.

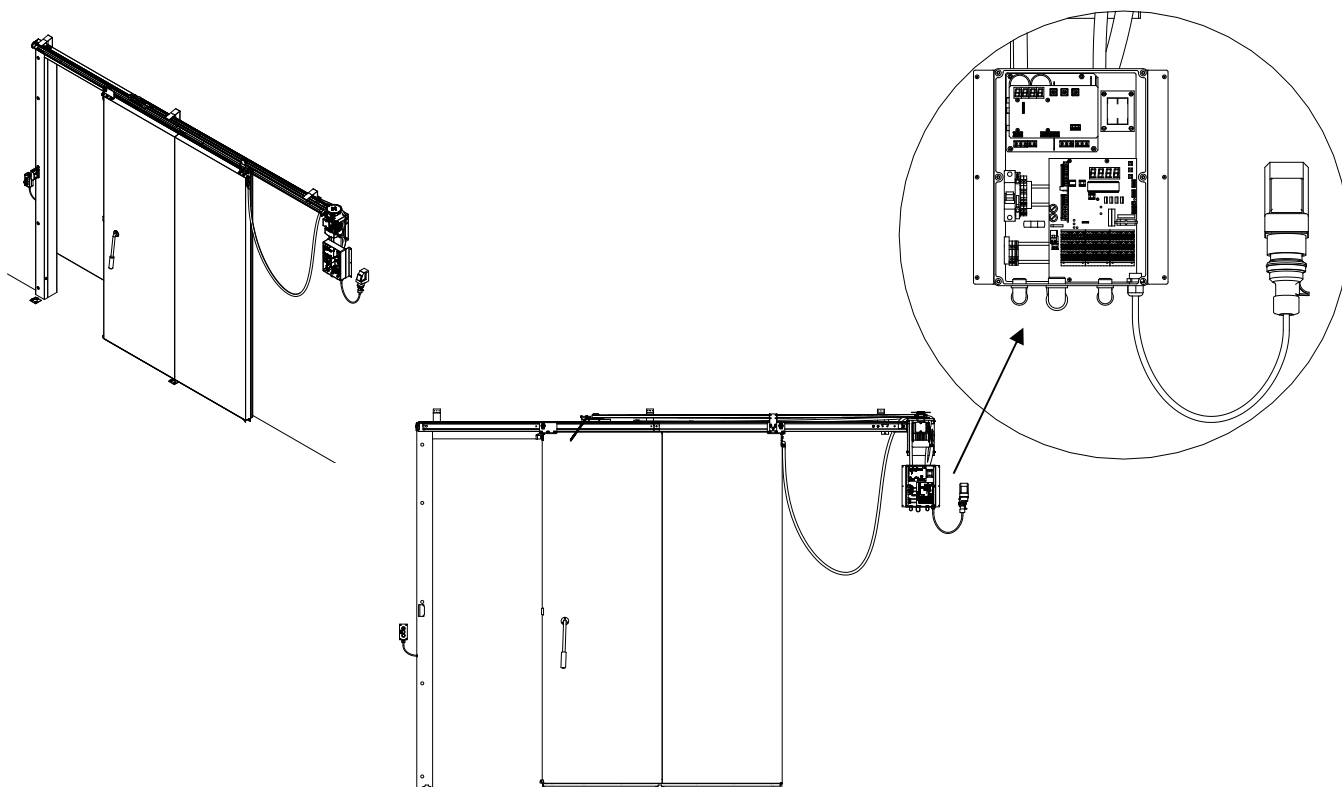

Final control after mounting

- Control that the frame and the stainless steel bottom guide are cleaned of concrete and dirt.
- The fire door is adjusted so that the sliding door closes easily and completely and covers the wall opening, both if the magnet is deactivated or if the door is closed manually.
- It is checked that the fire door has effortless, full movement throughout the opening.
- It is checked that the built-in handle does not hit the door frame or the wall when the fire door closes.
- Foil on frame and door is removed.
- Wheels should always be tightened.
- Stainless doors and frames should be oiled with oil intended for stainless doors and intended for the industry in which the door is installed.

Documentation

Check that the label is attached to the door. The label contains information about fire certification and potentially CE mark (if the door is CE marked).

Check that the following documents are delivered with the door:

- DoP, Declaration of Performance (if the door is CE marked)
- Operations and maintenance manual

Maintenance and service

An operations and maintenance manual is handed over when purchasing a door. The manual should be carefully read before the door is put to use.

Be aware that there may be a requirement for a statutory inspection of the door.