



# Operations and maintenance manual

Roller doors

## Content

---

General safety precautions .....	2
General information .....	2
Warnings .....	2
Roller door use .....	3
Overview of the industries in which the roller doors can be used:.....	3
Limited use .....	3
Unpacking.....	3
Mounting the roller door.....	3
Power-up of automatic door .....	4
Disposal.....	4
General information about roller doors.....	4
Technical specifications.....	5
Roller door projection .....	6
Definition of wall opening measurements and frame measurements.....	12
Functional descriptions (options) .....	13
Push panel.....	13
Pull chord.....	13
Radar.....	13
Radio control .....	14
Induction loop .....	14
Rat protection .....	14
Other options.....	14
Operations and maintenance .....	15
Statutory inspection .....	16
Repairing faults .....	16
Spare part list.....	17

## General safety precautions

---

### General information

---

This operations and maintenance manual applies automatic roller doors and must be read carefully before putting the door into operation. Be particularly attentive to the safety information. Door users must be thoroughly instructed in the use of the door. The description of the current door appears on the page before the table of contents. It is important to adhere to the service intervals to achieve the longest possible service life. Roller doors should be serviced by authorised service engineers.

This manual is primarily intended for operators, maintenance and cleaning personnel. The complete user manual for the door consists of an assembly guide (supplied only when Door System is not responsible for the assembly of the door, but can be found on the website), operation and maintenance manual and documentation for CE marking (if the door is CE marked).

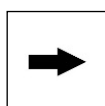



**There is a compulsory annual service inspection for roller doors.**

### Warnings

---

This manual contains warnings in the text at certain points, where the reader should be particularly attentive to personal safety or in relation to the operations of the equipment. Warnings are displayed according to the following:

 Caution	<b>Caution</b> Potentially harmful situation. Possible consequences: light or minor damages. The product or items close by could be damaged.
 Warning	<b>Warning</b> Potentially dangerous situation. Possible consequences: bodily harm or serious equipment damage.
 Note	<b>Note</b> Important information about a product or parts of the user manual requiring special attention.

## Roller door use

The roller door can be used in all kinds of industry to separate 2 rooms, with a need for quick open/close time. This may be due to differences in temperature, pressure, draft or obnoxious smells.

In principle, there are no limits as to how often the door is opened and closed, however, the time intervals between service and maintenance may vary depending on the door usage.

The door can be operated by a push-button signal or a signal from various remote controls.

The door has vertical opening and closing and can solely be fitted as such.

Modifications and changes to the door that might affect the safety on the door, is not allowed.

## Overview of the industries in which the roller doors can be used:

	Retail	Pharmaceutical industry	Food industry	Frost	Storerooms + others
DS260	X				X
DS290	X	X	X		X
DS291	X	X	X		X
DS300	X	X	X	X	
DS301	X	X	X	X	
DS305	X	X	X		
DS306	X	X	X		
DS320P		X	X		
DS350			X	X	
DS375			X	X	
DS700		X	X		X
DS800		X	X	X	
DS850		X	X	X	
DS855		X	X	X	

## Limited use



Staying in the door opening is discouraged, as you risk the door closing if the photocells are not activated.

## Unpacking

Usually, the doors are delivered in a crate wrapped in plastic.

If the door is not mounted upon receipt, it should be stored indoor and protected against moisture and variation in temperature.

Check if the packaging is intact before unpacking the door. If the packaging is damaged, thoroughly examine the content for damages.

In case of damages, inform both the haulage contractor and Door System. The damages must be documented in a report including pictures to be sent immediately to Door System.

## Mounting the roller door

In cases, where the roller door is not mounted by Door System's own service engineers, instructions for mounting are included in the package. Also available at [www.doorsystem.dk](http://www.doorsystem.dk)



It is the customer's responsibility that the wall opening measurements matches the order

confirmation, unless it was measured by Door System's own staff.

### Power-up of automatic door

---

We refer to the separate door operations manual to be found in the electric box.

### Disposal

---

The door must be disposed of according to the national environmental legislation and regulations in force at the time in question.

### General information about roller doors

---

A roller door comprises of 2 frame legs, a top roller, a door leaf, shielding and a control box. The various models are developed for storerooms/shops, for moderate hygiene demands, high hygiene demands and demands in pressure difference as well as for freezer rooms.

The door opens either by push-button panel, pull chord, radar, induction loop or via remote control. See descriptions of these functions in the section "Functional descriptions (options)".

In roller doors with a bottom rail, a horizontal photocell is mounted. The photocell is built into the bottom rail and if activated while the door is closing, the door will open.

Likewise, there is a photocell located 250 mm above the floor in the frame leg. If this is activated, the door will return to its open position.

These photocells ensure that the door does not close, when the photocells are activated, thereby avoiding squeezing.

The photocell in the frame leg can also be used to find the reference point of the door leaf (see more in the door operations manual).

Description of the delivered door is placed in the front of this document.

## Technical specifications

Door types:	DS260 - DS290 – DS291 - DS300 – DS301 - DS305 – DS306 - DS320 - DS350 - DS375 - DS700 - DS800 - DS850 – DS855
Fabric thickness:	0,6 mm – 2 mm - 43 mm
Frame material:	Stainless, galvanized or painted steel profile. DS260: aluminium
Safety devices:	Photocell in frame leg Sensor in bottom profile (not DS700-DS800-DS850-DS855) Collision protection Extra wind protection (option) Emergency stop
Opening speed:	Variable until 0,6 m/s or 2 m/s depending on the type (can be adjusted)
Closing speed:	Variable
Steering:	CPU construction. Error indicator and frequency converter is standard.
Voltage:	230 V
Power:	16 Amp
Motor:	0,75 kW, 1,5 kW or 2,2 kW
Impulse indicator:	Push panel with standard emergency stop.
Operating temperature:	-20°C to +40°C.
Options:	Pull chord Radar Radio control Induction loop Battery backup Window Insect net

Roller door projection

**DS260**

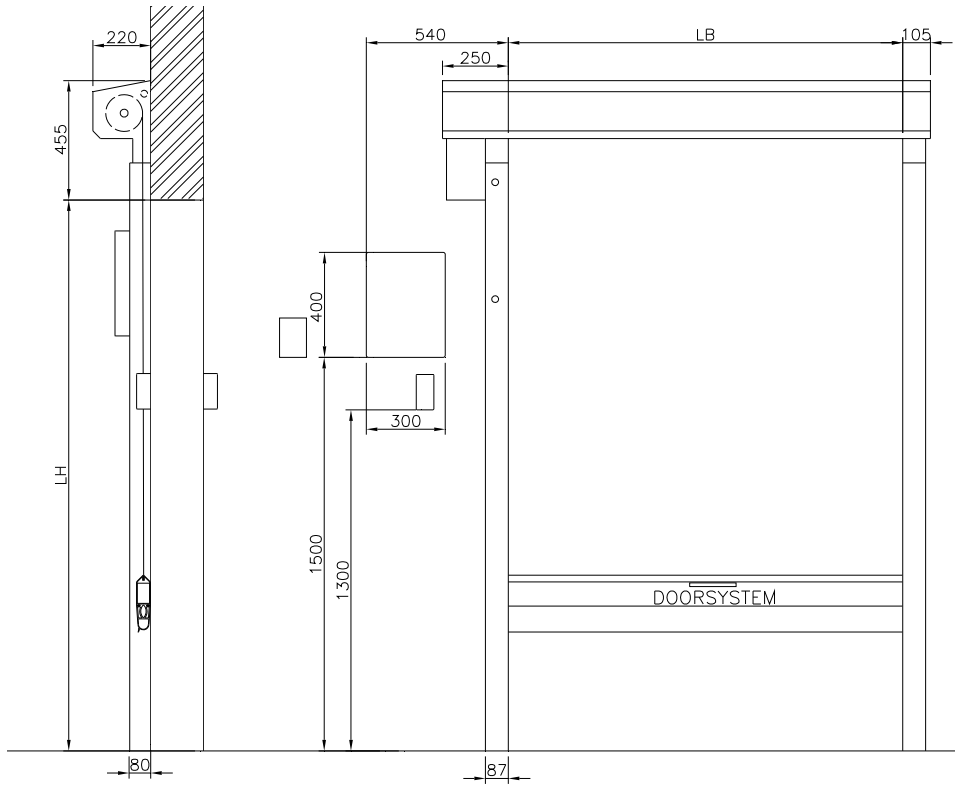

**DS290**

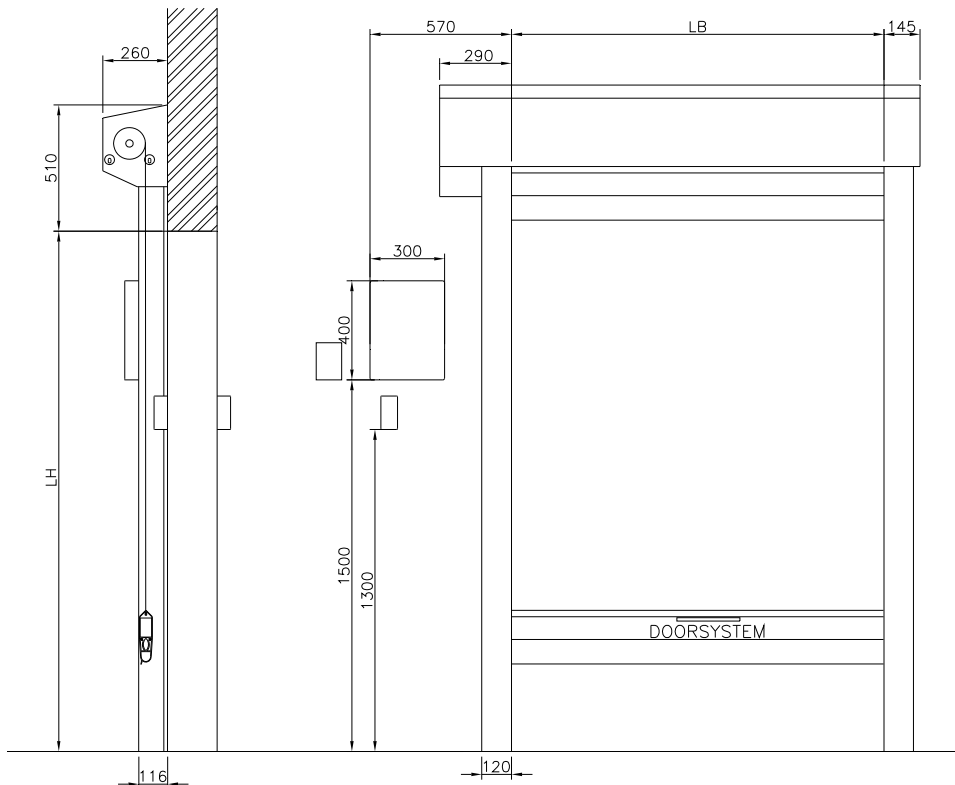

**DS291+DS301**

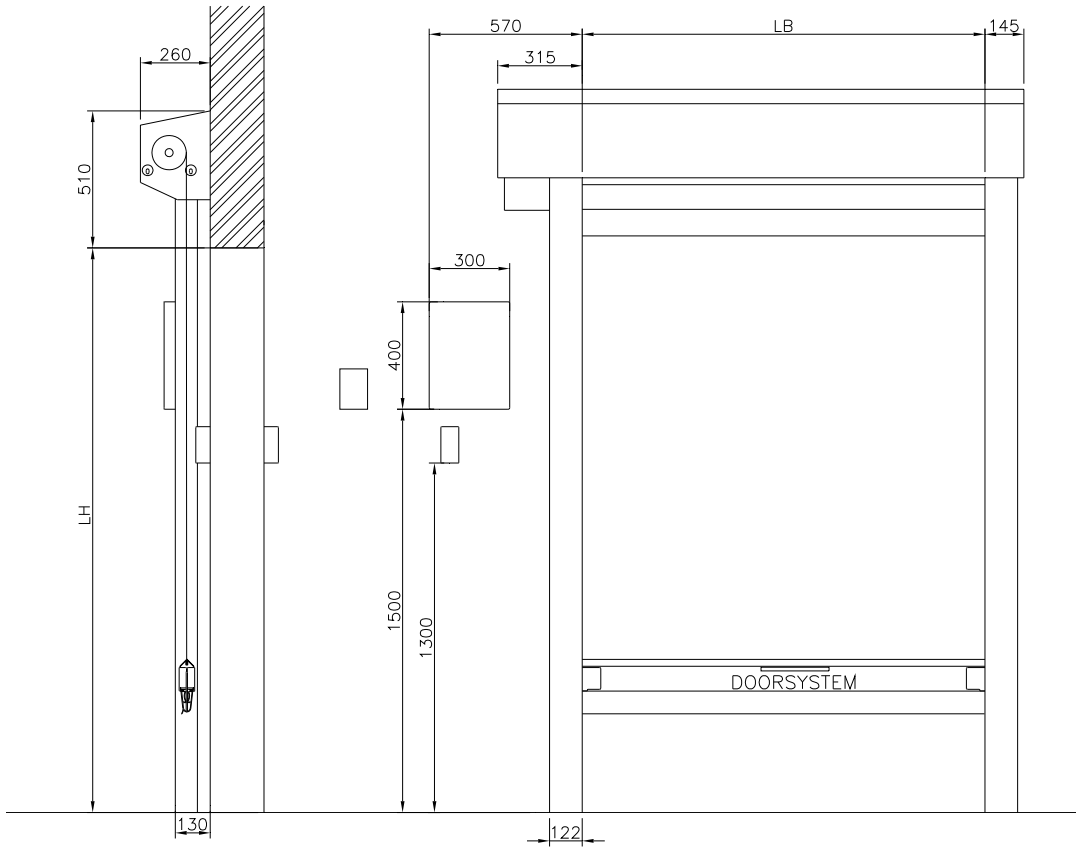

**DS300**

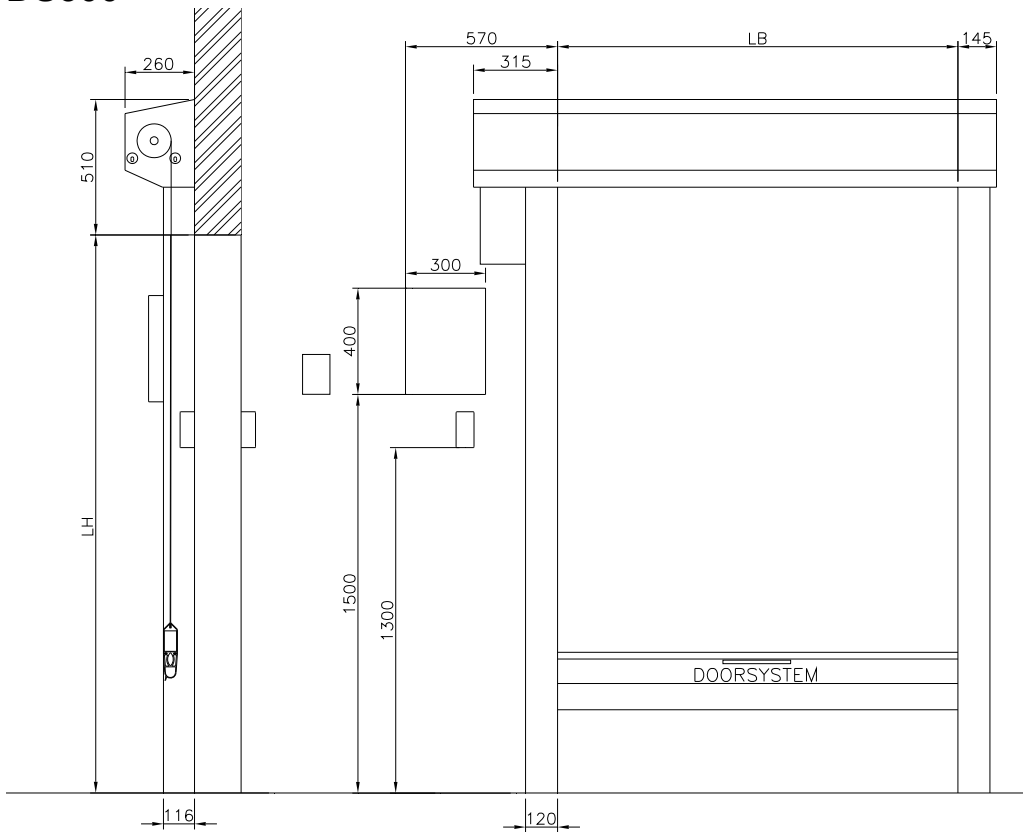



**DS305**

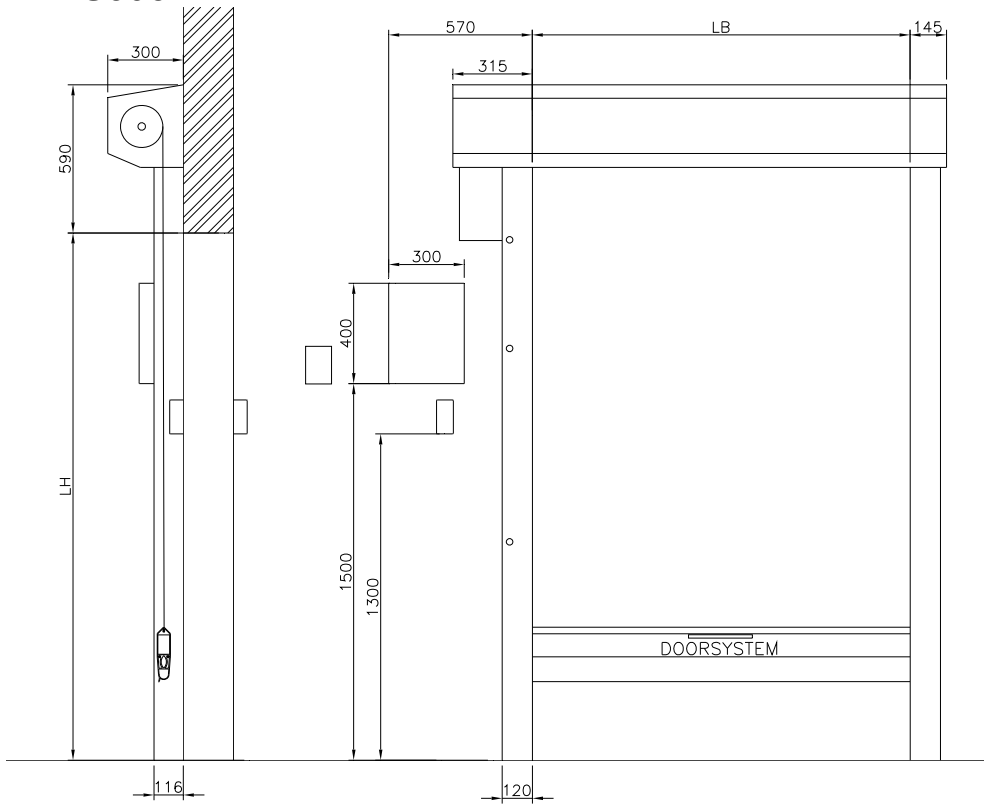

**DS306**

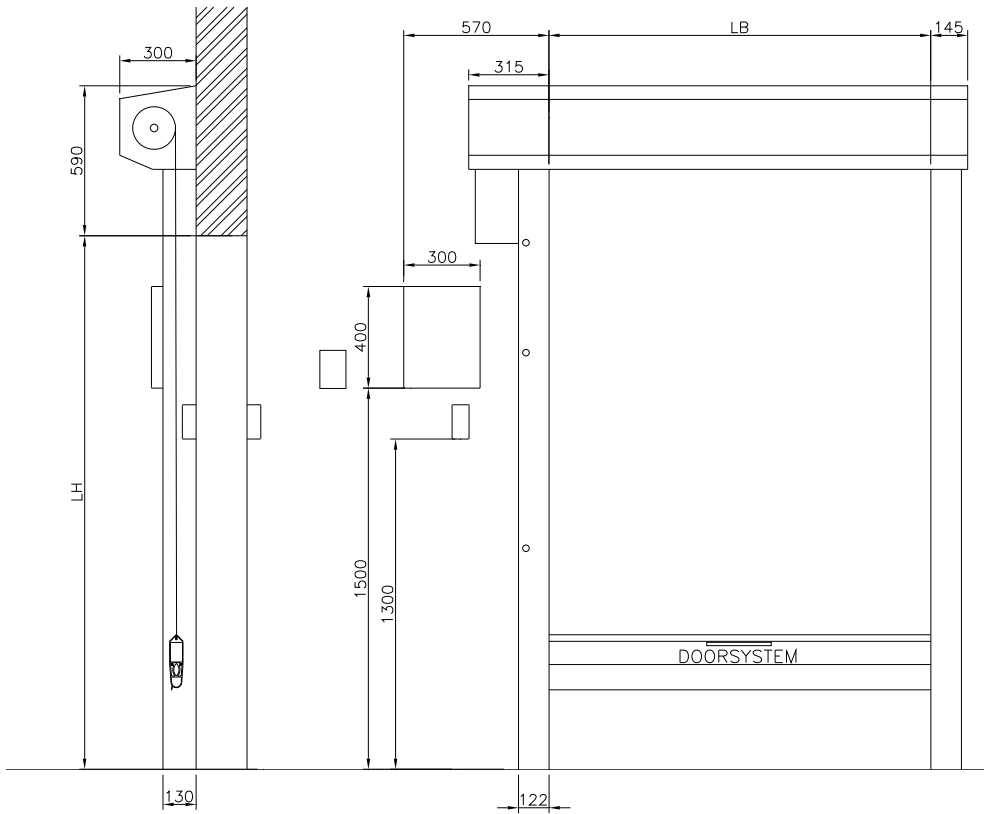

**DS320**

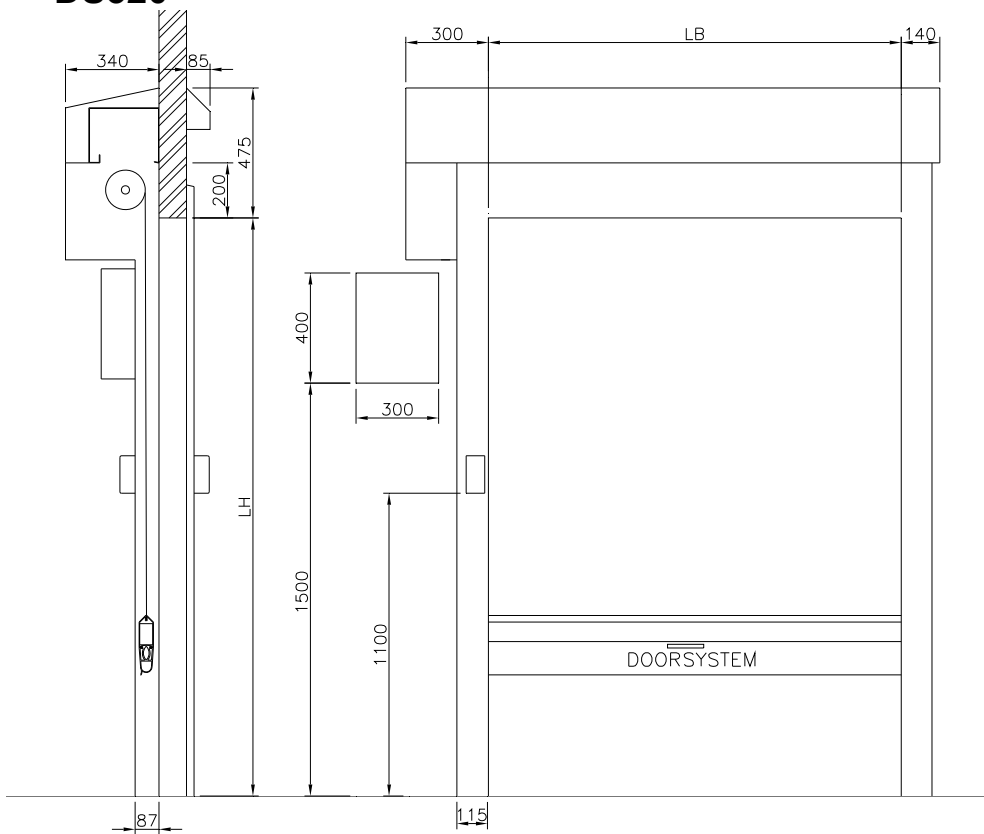

**DS350**

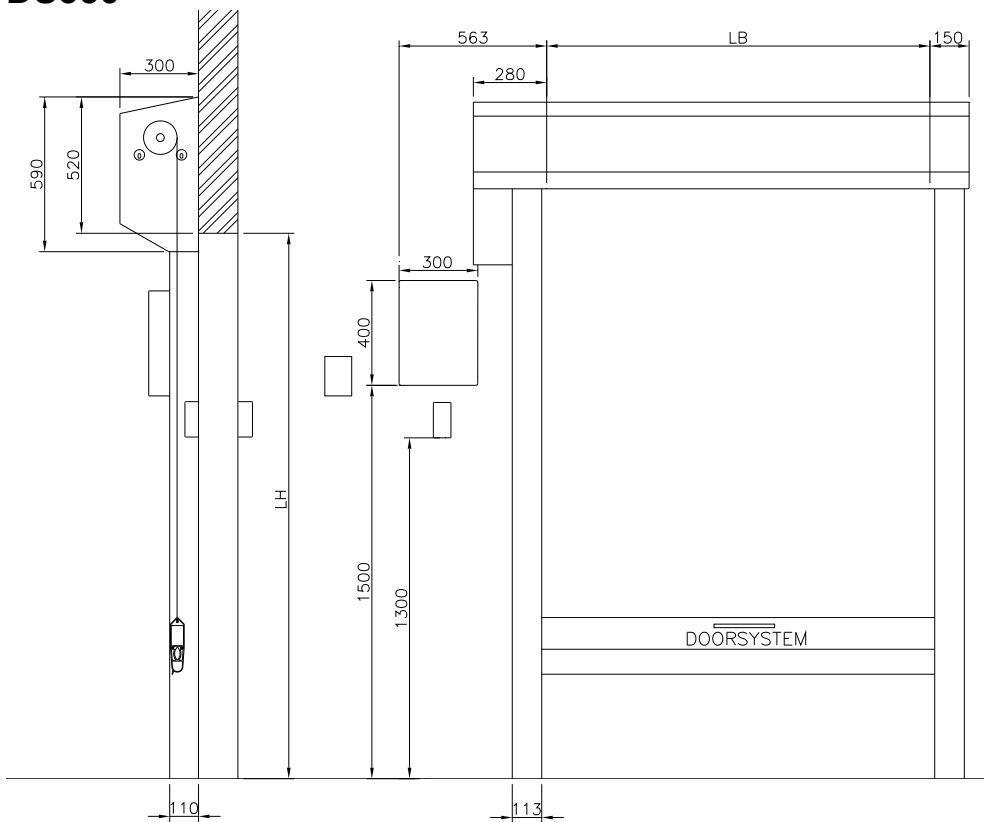

**DS375**

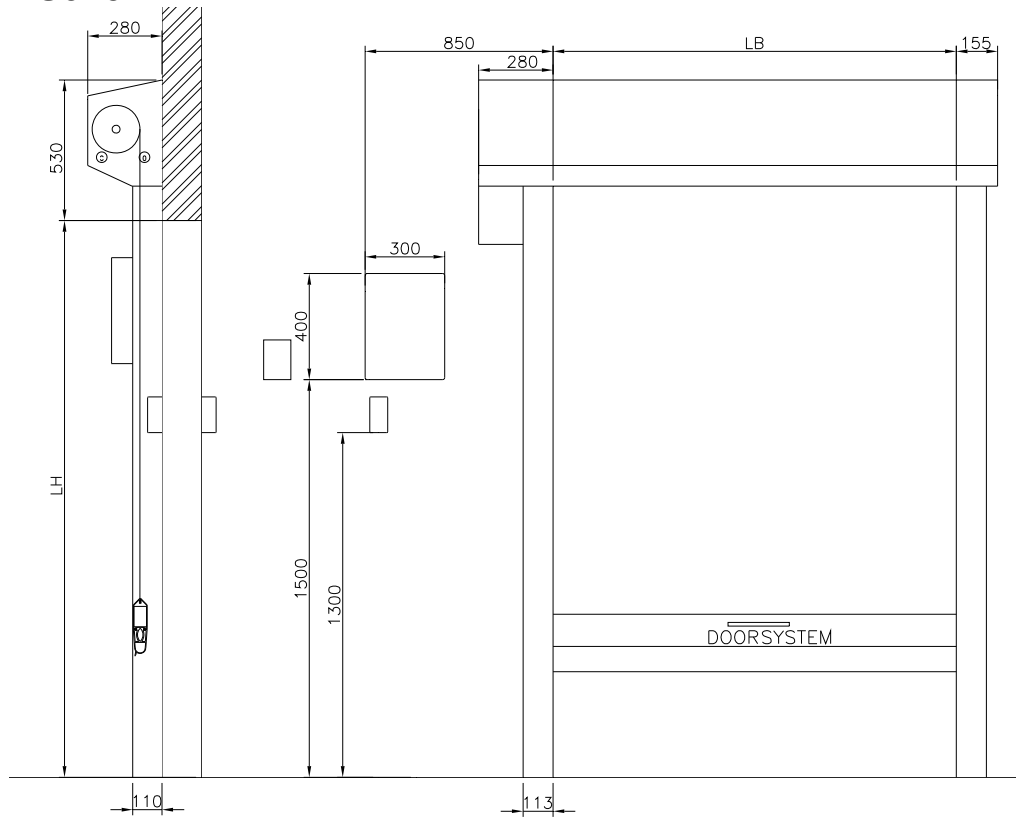

**DS700**

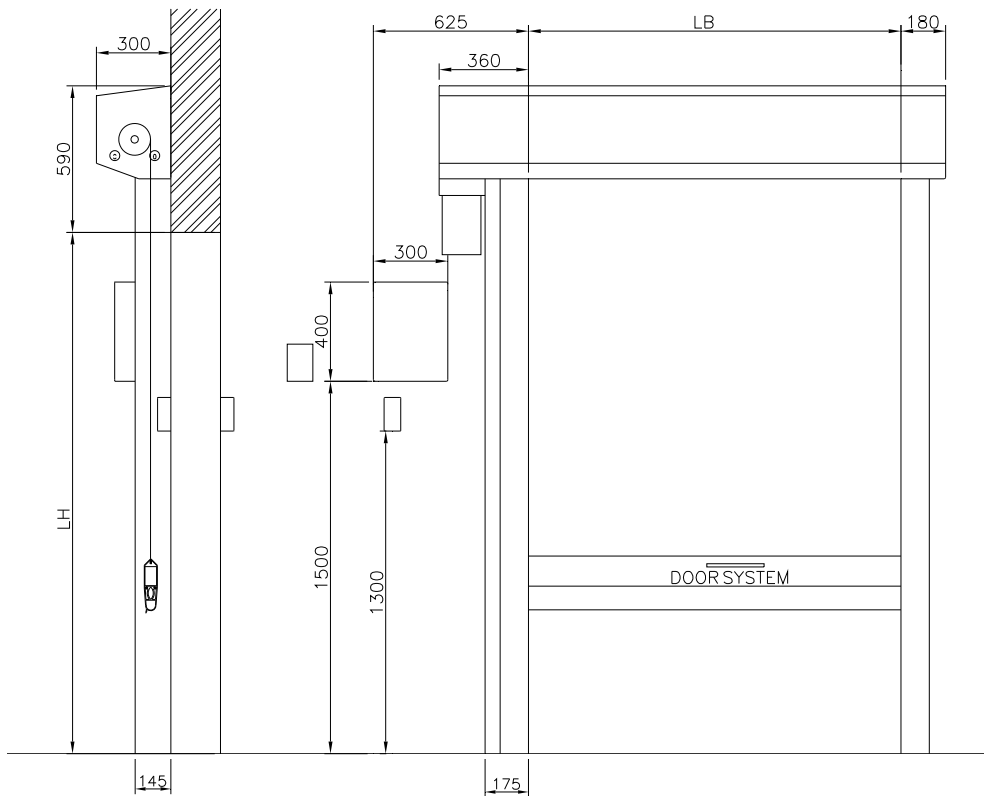

**DS800**

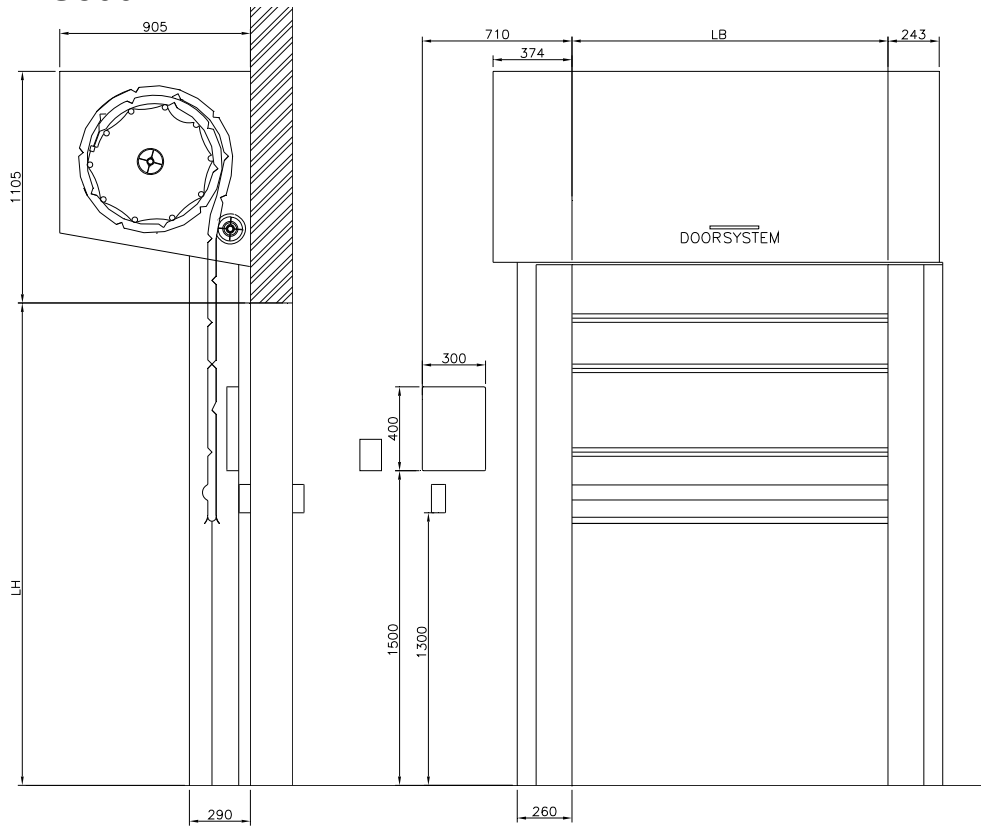

**DS850+DS855**

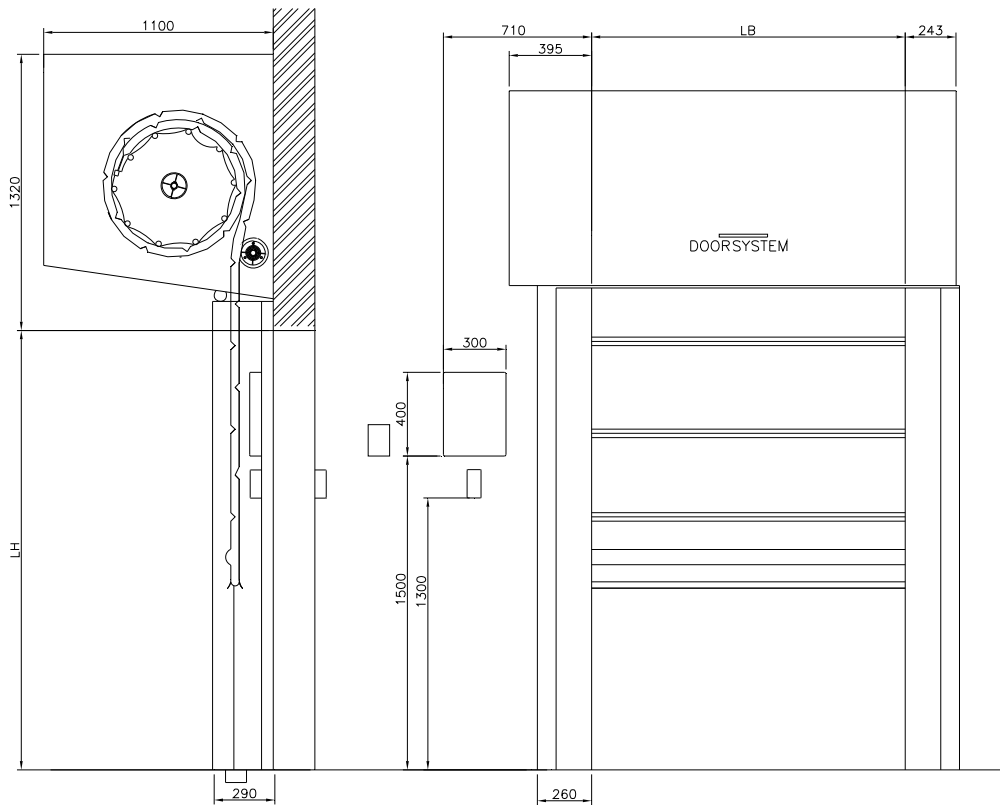

Definition of wall opening measurements and frame measurements

**Wall opening measurement:**  
Vertical distance between the walls, the horizontal distance between floor and top of the and the thickness of the wall is called the WALL OPENING MEASUREMENTS.

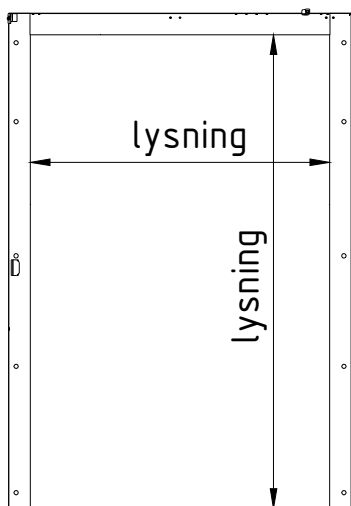
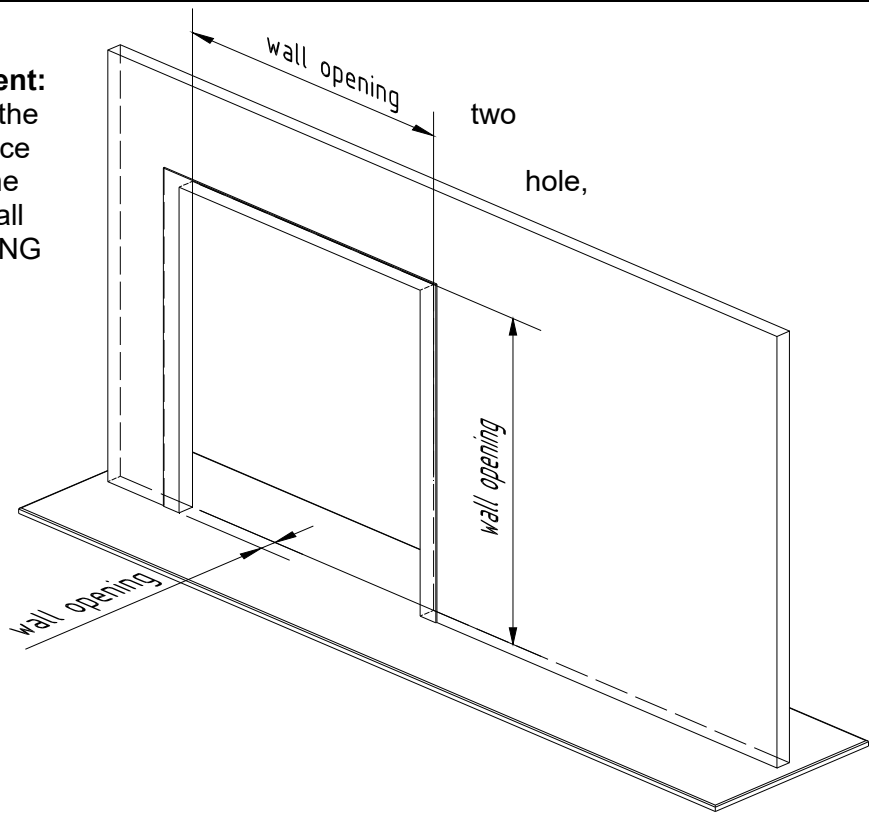



**Clear opening:**

Vertical distance between the 2 frames at the side of the door and the horizontal distance between the bottom of the top frame and the floor/threshold is called the Clear opening. In other words, the light visible through the hole.

## Functional descriptions (options)

### Push panel

The push panel is always delivered with an automatic door. The panel is a box with push-buttons mounted on the wall next to the door. There is a push-button for opening, one for closing and an emergency stop. With a single push on the close-button, the door closes from completely open to completely closed and can only be stopped by activating photocells, open-button or the emergency stop. With a single push on the open-button, the door opens from completely closed to completely open. The door cannot be stopped by activating the photocells but can be changed by pushing the close-button or emergency stop.

	<p><b>Located on the back of the door opening.</b></p> <p>White push-button = open (regardless of opening direction)</p> <p>Emergency Stop</p> <p>Black push-button = close (regardless of closing direction)</p>		<p><b>Located on the front of the door opening.</b></p> <p>White push-button = open (regardless of opening direction)</p> <p>Emergency Stop</p> <p>Yellow light push-button = close (regardless of closing direction) When the button lights up, this indicates a stoppage outside normal operations.</p>
--	---	---	---

*If the emergency stop has been activated, the button must be turned clock-wise to release the emergency stop.*

### Pull chord

The door is opened by pulling a chord and closes automatically after a certain period of time. The time is set on the timer. This means that even if the door is already open, the pull chord must still be activated, or the door might begin to close while you are moving through it. The pull chord can also be set at a tilt function, meaning that the pull chord must be activated when opening the door and again when closing the door.

### Radar

The radar can be used either for safety or to activate the door.

If the radar is used as safety radar, it will always open, if the door is active, when there is movement in front of the door. If the radar is used to activate the door, the door will open when there is movement within the radar's "visual field". The door will close after at given period of time. The time is set on the timer.

It is possible to install safety radar on one side of the door, and open/close radar on the other side of the door. This is to provide extra certainty of avoiding damages to persons or materials.

## Radio control

---

Radio control is a remote control of the door, often utilised in locations with truck traffic.

## Induction loop

---

Magnetic field, which is buried in the floor. It registers when metal enters the area and opens the door. The door will close after at certain period of time. The time is set on the timer.

## Rat protection

---

Also known as "rat mode". A time setting in the control ensuring that the door closes completely when it has been inactive for a certain period of time. Often used in slaughterhouses.

## Other options

---

It is possible to deliver the door with the following:

- Battery backup: Used when you wish to operate the door during power failure.
- Window: A piece of the door leaf is replaced with a plastic window. This is useful when you wish to be able to look through the door.
- Insect net: A piece of the door leaf is replaced with an insect net. This is useful when you desire a sound air flow between two rooms.

## Operations and maintenance

Ongoing preventive maintenance is essential for the operation of the door. If some parts does not function as intended, the safety and functionality of the door can be disturbed.

The best way to secure the optimal conditions for the door, to make sure the safety on the door is ok and to optimize the lifetime of the component in the door are by continuously maintenance of the door. The maintenance of the door should be performed regularly and minimum as described below. The life expectancy of the door is up to 30 years when regular maintenance is performed.

It is the responsibility of the owner of the building to maintain the door as described below. Annual service inspection is statutory on automatic doors.



*For the daily operations to be as smooth as possible, it is important that the maintenance items below are checked/carried out regularly.*

	Subject	Control item	Control:					
			Visual -ly	Annual -ly	Bi- annually	Quarter -ly	Month- ly	Daily
1	Rubber lists	Damaged rubber lists should be replaced.	X				X	
2	Photocells/radar/DW-contact	Photocells must be checked. This is done by holding something in front of the photocell in order to return the door to its open position. Photocells in the bottom rail are activated by pushing the rubber list up, while the door is moving down.	X					
8	Emergency stop	Emergency stop must be checked. This is done by activating the emergency stop and checking that the gate stops.	X					X
3	Frame	In case of ice on the frame, remove ice.	X					X
4	Heating wires	Check at the heating wires work by feeling the frame. The frame must be free of ice.	X					X
5	Battery backup	The battery must be replaced every 2 years. The battery is checked by turning off the power supply to the port.			X			
6	Accidental stress	If the door is subjected to collision that may have damaged the safety devices ensuing a risk of personal injury, an inspection must be carried out.	X					



	Subject	Control item	Control:					
			Visual ly	Annual ly	Bi-annually	Quarter ly	Month ly	Dai ly
8	Stoppages	In case of stoppages, control the display, see the door operations manual or contact DoorSystem A/S						
9	Spare parts	When ordering spare parts the door number should be stated. The door number is located on the door sign, attached to the door.						
10	Cleaning	Wash with mild soapy water. Wash with a soft brush and rinse with clean water. Wiping required. Under no circumstances clean with agents containing solvents (gasoline, thinner, alcohol or similar), abrasive or polishing agents, or wax, as these will reduce the product's service life. When using chlorine-containing cleaning agents, thorough washing must be carried out. Prolonged presence of chlorides on the surface of the door will reduce the surface's overall service life. For thorough cleaning, use a cleaning agent designed for stainless steel and aluminium.						
11	Lubrication	Once cleaned, stainless surfaces are covered by acid-free oil, approved for the industry where the door is fitted.						
12	Before putting the door into operation	Once mounted, remove the foil from the frames and lubricate with acid-free oil until the steel is saturated. This is done to avoid rust film and other substances getting stuck on the surface. Repeat this treatment after each cleaning, which could wash off the oil.						

\*Not available for all door types.

## Statutory inspection

Annual statutory inspection includes the following:

- Automatic doors
  - Checking that the door is in a safe condition in terms of safety and health
  - The inspection must be carried out by an expert





For a warranty on the doors, an inspection by Door System A/S is required (when creating a service agreement).



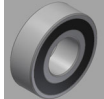
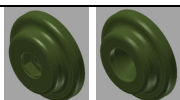

***Please direct any questions about the operations and maintenance to Door System's service department at +45 86 92 11 71.***

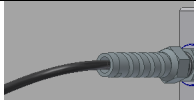
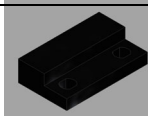

## Repairing faults

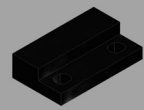
PROBLEM	POSSIBLE CAUSE	ERROR CORRECTION
The door will not open/close	Lack of power	Check to see if the power for the control is on. If not, switch on.
	The emergency stop may have been activated	Release the emergency stop by turning the red button to the right.
	The safety functions may be blocked	Check if the door frame and bottom rail photocells are correctly adjusted and if they are dirty.

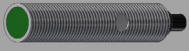
## Spare part list

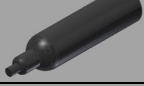
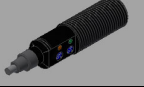
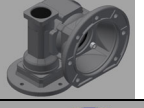
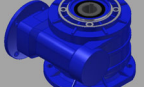
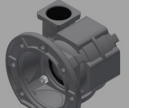
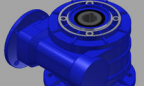
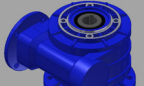
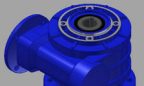
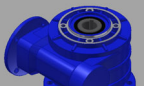
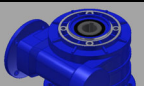
No.	Description	Item no.	
1	Perforated disc for sensor, oblong hole, DS 260-700	27-0009	
	Perforated disc for sensor, oblong hole, DS800	27-8010	
2	Bearing SB-205 Ø25 mm (DS260 - DS290)	27-2895	
3	Bearing SB-206 Ø30 mm (DS300 - DS850)	27-2896	
4	Bearing 6202.2RS 15x35x11 (DS700)	27-2897	
	Stainless version: Bearing 6202.2RS 15x35x11 AISI 304 (DS700)	27-2898	
5	Wind protection wheel type DS, 1 set	27-4023	
6	Belt type E12/2 green for roller door	27-4030	
7	Pull spring frame leg L 650 DS500-700 R/S	27-6090	
	Pull spring frame leg L 800 DS500-700 R/S	27-6091	
	Pull spring DS L= 1200 mm for counterbalanced	27-6092	
	Pull spring DS L= 2000 mm for counterbalanced	27-6093	
	Pull spring DS L= 1350 mm for counterbalanced	27-6094	
	Pull spring DS L= 1000 mm for counterbalanced	27-6095	
	Pull spring DS L= 1600 mm for counterbalanced	27-6096	
Pull spring frame leg L 550 DS500-700 R/S	27-6099		
8	Wire wheel bottom Ø100 mm (DS700)	27-7065	
9	Sealing strip DS-RP black	42-0050	
10	Heating cables (see length on door sign) (DS800 - DS850)	50-0xxx	
11	Spiral wire DS 7 conducted 400mm/3m	84-0001	
	Spiral wire DS 7 conducted 750mm/3m	84-0008	
	Spiral wire DS 7 conducted 750mm/8m	84-0009	
12	Magnet 14x23	84-0207	

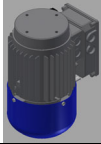
No.	Description	Item no.	
13	Magnet 14x23	84-0207	
14	Magnet sensor 14x23	84-0208	
15	Proximity sensor 2 M	84-0212	
16	Proximity sensor 5 M	84-0213	
17	MIG encoder 140-24-50-5 (DS850)	84-0216	
18	Receiver/fitting R15R 30 mm	85-1030	
19	Transmitter T15RP R30	85-1032	
20	Diffuse photocell 18 mm (DS290-DS305)	85-1039	
21	Gear type Tramec 40 1:15 RP (DS260-DS290)	85-1233	
22	Gear type RMI 50 1:10 RP Frimodt (DS375)	85-1238	
23	Gear type Tranec 50 1:7.5 RP Frimodt (DS300-DS350)	85-1239	
24	Gear type RMI 50 1:7 RP Frimodt (DS700)	85-1240	
25	Gear type RMI 70 1:28 (DS800)	85-1244	
26	Gear type RMI 85 H 1:40 (DS850)	85-1245	
27	Gear type RMI 85 V 1:40 (DS850)	85-1246	
28	Gear tp. RMI 110 H 1:40 (DS855)	85-1276	

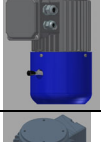
No.	Description	Item no.	
29	Motor with brake MT-Mar 0.75 kW 2800 rpm (DS260-DS290)	85-1284	
30	Motor with brake Vem 1.5 kW 1500 rpm (DS300-DS800)	85-1286	
31	Motor with brake MT-Mar 1.5 kW 1500 rpm (DS300-DS700)	85-1288	
32	Motor with brake, Vem 2.2 kW.1500 rpm (DS850)	85-1289	